



# Siding - Vertical Installation Guide

v20210114US



# **CONTENTS**

<a href="#"><u>Important Note</u></a>	3 - 5
<a href="#"><u>Siding Parts</u></a>	6 - 8
<a href="#"><u>Under Construction</u></a>	9
<a href="#"><u>Joist Installation</u></a>	10
<a href="#"><u>Expansion and Contraction Values Table</u></a>	11
<a href="#"><u>Locking the Siding Board</u></a>	12 - 15
<b>Siding Vertical Installation</b>	
- <a href="#"><u>Framing</u></a>	16 - 17
- <a href="#"><u>Installation between the Outermost Edge &amp; the Inside Corner</u></a>	18 - 22
- <a href="#"><u>Installation between the Inside Corner &amp; the Outside Corner</u></a>	23 - 26
- <a href="#"><u>Installation between the Outside Corners</u></a>	27 - 30
- <a href="#"><u>Installation between the Outside Corner &amp; the Outermost Edge</u></a>	31 - 35
- <a href="#"><u>Finish The Top</u></a>	36

NOTE: Click on the heading to enter the section directly

### IMPORTANT Note:

## Read All Sections Before You Start

For the most up to date information, please visit our website @ [www.newtechwood.com](http://www.newtechwood.com)

Prior to installing any composite siding system, it is recommended that you check with local building codes for any special requirements or restrictions. The diagrams and instructions outlined in this guide are for illustration purposes only and are not meant or implied to replace a licensed professional. Any construction or use of NewTechWood must be in accordance with all local zoning and/or building codes. The consumer assumes all risks and liability associated with the construction and use of this product.

### Safety

When dealing with any type of construction project, it is necessary to wear appropriate safety equipment to avoid any risk of injuries. NewTechWood recommends, but is not limited to the following safety equipment, when handling, cutting, and installing NewTechWood: gloves, a respiratory protection, long sleeves, pants, and safety glasses.

### Tools

Standard woodworking tools may be used. It is recommended that all blades have a carbide tip. Standard stainless steel or acceptable coated deck screws and nails are recommended.

### Environment

A clean, smooth, flat, and strong surface is needed to install NewTechWood's products correctly. Please check with local building codes before ever installing any type of siding. If installation does not occur immediately, NewTechWood's products need to be put on a flat surface at all times. It should NEVER be put on a surface that is NOT flat.

### Planning

Plan a layout for your siding before starting it to ensure the best possible looking siding for your project. Building codes and zoning ordinances generally apply to permanent structures, meaning anything that is anchored to the ground or attached to the house. So nearly every kind of siding requires permits and inspections from a local building department. We recommend drawing out a site plan of your proposed project that you intend to do to minimize errors and make your perfect Siding.

**Pressure wash on a scrap piece of material before using a pressure washer on the deck to make sure that your settings will not damage the Ultrashield coating.**

### Construction

NewTechWood UltraShield is NOT intended for use as columns, support posts, beams, joist stringers, support against a force, or other primary load-bearing members. NewTechWood must be supported by a code-compliant substructure. While NewTechWood products are great for retrofits, NewTechWood's products CANNOT be installed on existing siding boards.

## Static

Static can also be more prevalent in areas that are of higher altitude because the humidity is lower. For these areas, be careful of using conductive objects such as metal railing and chairs as static shocks might occur more often. A potential way to lower the amount of static shocks occurring is to apply Staticide ([www.aclstaticide.com](http://www.aclstaticide.com)) on your deck or use anti-static mats before doorways.

## Ventilation

NewTechWood products CANNOT be directly installed onto a flat surface. It must be installed onto a substructure, so there is adequate and unobstructed air flow under the cladding to prevent excessive water absorption. A minimum of 1" (25mm) of continuous net free area under the siding surface is required for adequate ventilation on all siding, so air can circulate between adjacent members to promote drainage and drying.

## Heat and Fire

Excessive heat on the surface of NewTechWood products from external sources such as but not limited to fire or reflection of sunlight from energy efficient window products. Low-emissivity (Low-E) glass can potentially harm NewTechWood products. Low-E glass is designed to prevent passive heat gain within a structure and can cause unusual heat build-up on exterior surfaces. This extreme elevation of surface temperatures, which exceeds that of normal exposure, can possibly cause NewTechWood products to melt, sag, warp, discolor, increase expansion/contraction, and accelerate weathering.

Current or potential NewTechWood customers that have concerns about possible damage by Low-E glass should contact the manufacturer of the product, which contains Low-E glass for a solution to reduce or eliminate the effects of reflected sunlight.

## Fasteners

When fastening NewTechWood's products all screws that are face fastened should always be driven in at a 90 degree angle to the siding surface. Toe nailing/screwing should never be done to the products. An extra joist should be added if a 90 degree angle cannot be driven into the board. All fasteners should be on their own independent joists, when two boards ends meet each other there must be a sister joist. The end of each board must sit on its own joist.

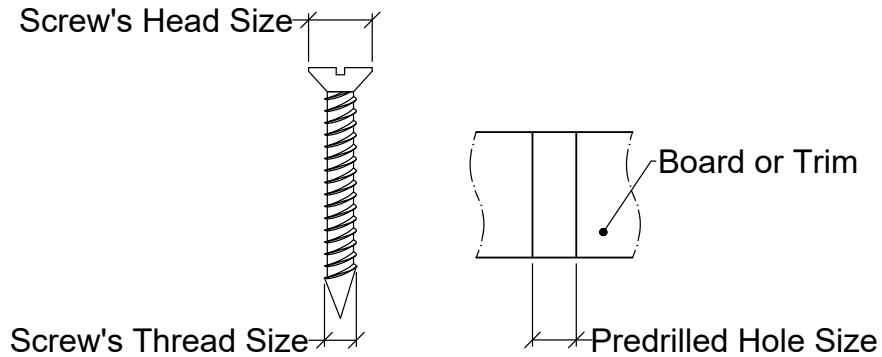
Use white chalk, straight boards, or string lines as templates for straight lines. NEVER USE COLORED CHALK. Colored chalk will permanently stain NewTechWood's products and are highly not recommended.

All nails/screws that are face fixed should always be stainless steel. Depending on the screws that you use when face fixing, there could be potential bulging or mushrooming. It is recommended to take care of these mushrooms/bulges by taking a rubber mallet and patting them down to give your siding a better look.

When choosing which screws/nails to use, always check first with your local home centers and hardware stores to see if they have screws that are engineered specifically for composite wood. These screws/nails will always work and give NewTechWood's products the best looking outcome, using other screws/nails that are not recommended for composite could potentially damage/harm the cladding. If you are unsure which screw/nail to use, contact your manufacturer for more information.




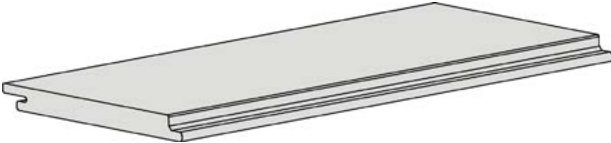
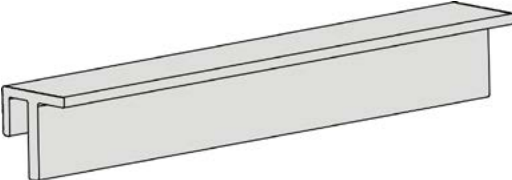
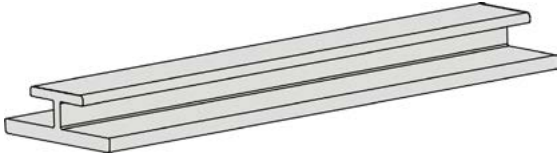
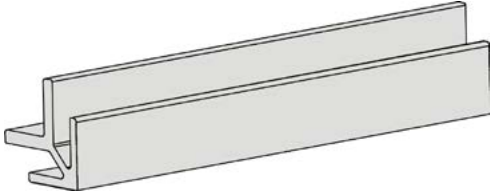
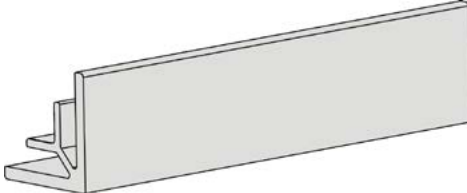
## Predrill

It is recommended to use the #8 pan head screw for face fixing the boards and the trims onto the joist. When face fixing, it is recommended to predrill a slightly bigger hole on the board and the trim to allow for expansion and contraction, as shown in below diagram,



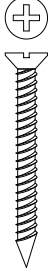
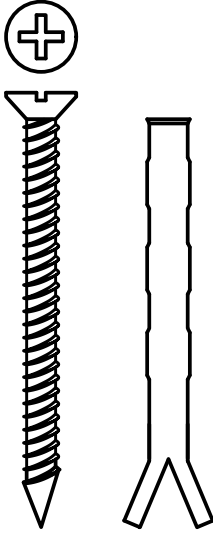
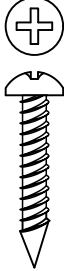
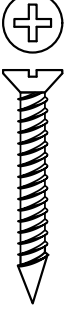
The predrilled hole size should be larger than the screw thread size, from  $1/16''$  (1.5 mm) to  $5/64''$  (2 mm). Moreover, the predrilled hole size should also be smaller than the screw head size, at least  $5/64''$  (2 mm). A washer can be applied if the predrilled hole size is smaller than the screw head size below  $5/64''$  (2 mm).

## Siding Parts

Product	Purpose	Part
<b>AW-02</b>	Used for the installation of the first board	
<b>AW-08</b>	Used at every joist to fix each board to the joist	
<b>T-7</b>	Used on the last Siding board	
<b>US09</b>	Siding Board (can be used in place of US30, US31)	
<b>US44</b>	F-Trim, used on the outermost edges	
<b>US45</b>	I-Trim, used if there is a break between two boards to cover up the gap	
<b>US46</b>	Outside Corner Trim, used on the outside corners	
<b>US47</b>	Inside Corner Trim, used on the inside corners	

# Siding Screws (For Wood Joist)


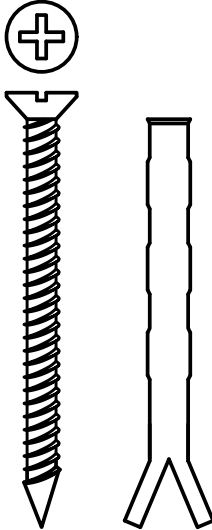


The table below shows the screws recommended to use for the installation, but not included.

Product	Purpose	Part
<p><b>#5 x 1 1/4"</b> <b>Stainless Steel</b> <b>SS304</b></p>	<p>Used when locking the board into the Clip (AW08)</p>	
<p><b>#8 x 3"</b> <b>Stainless Steel</b> <b>SS304</b> <b>**depends on the thickness of your joists</b></p>	<p>Used when installing the joist onto the wall</p>	
<p><b>#8 x 1"</b> <b>Stainless Steel</b> <b>SS304</b> <b>(Pan Head)</b></p>	<p>Used when installing the Clip (AW08) and the Rubber Stopper (T-7) onto the wood joists</p>	
<p><b>#8 x 1 1/4"</b> <b>Stainless Steel</b> <b>SS304</b> <b>(Flat Head)</b></p>	<p>Used when face fixing the boards and the trims onto the wood joists</p>	



## Siding Screws (For Aluminum Joist)

The table below shows the screws recommended to use for the installation, but not included.

Product	Purpose	Part
<b>#5 x 1 1/4"</b> <b>Stainless Steel</b> <b>SS304</b>	Used when locking the board into the Clip (AW08)	
<b>#8 x 3"</b> <b>Stainless Steel</b> <b>SS304</b> <b>**depends on the thickness of your joists</b>	Used when installing the joist onto the wall	
<b>#8 x 1"</b> <b>Stainless Steel</b> <b>SS410</b> <b>(Pan Head)</b>	Used when installing the Clip (AW08) and the Rubber Stopper (T-7) onto the aluminum joists	
<b>#8 x 1 1/4"</b> <b>Stainless Steel</b> <b>SS410</b> <b>(Flat Head)</b>	Use when face fixing the boards and the trims onto the aluminum joists	

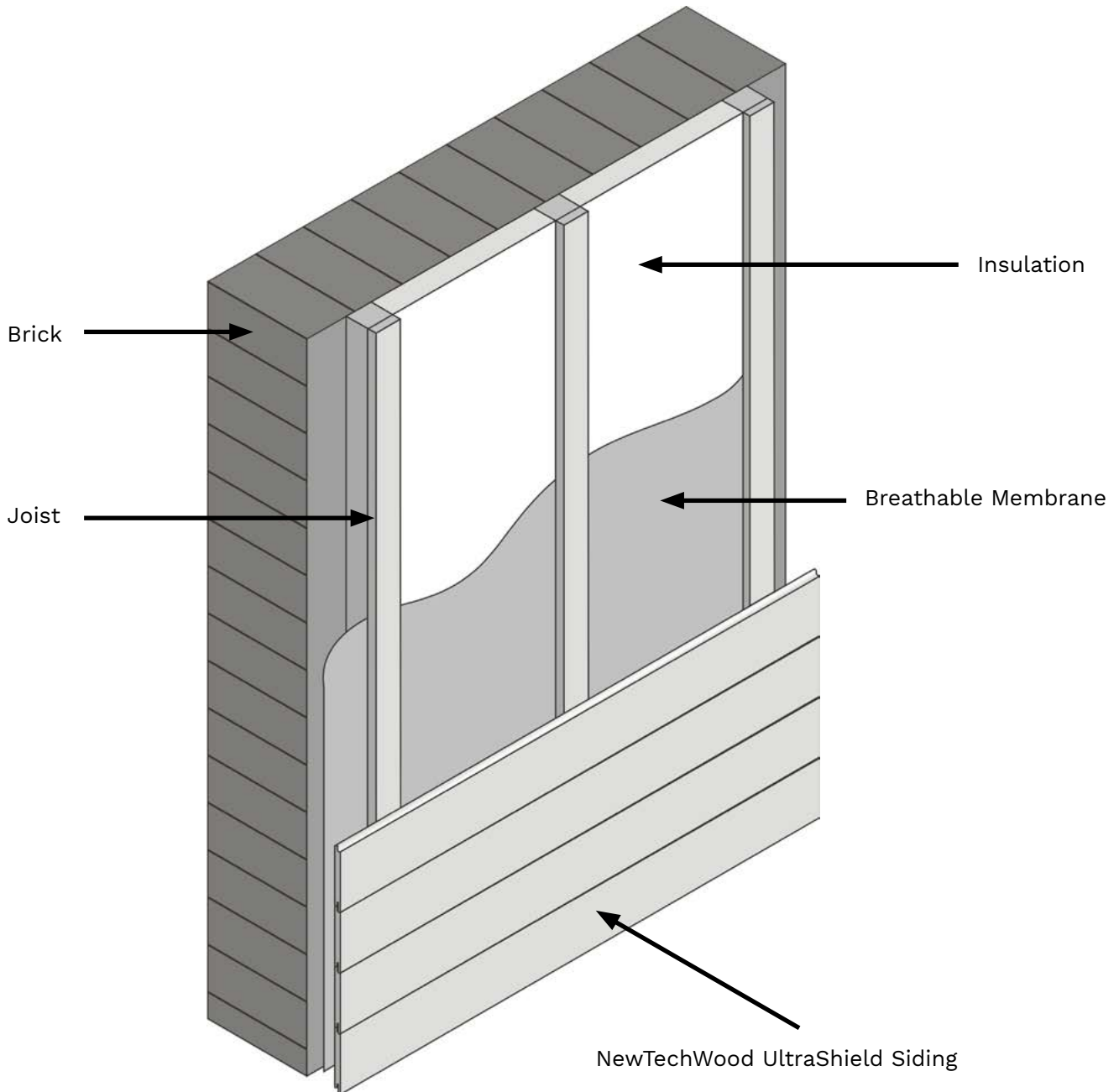
\*Note: All screws are based on our recommendation and if the installation requires something different than what is shown, a professional should be consulted before installing.

The following installation guide will use the above screw sizes.



## Under Construction

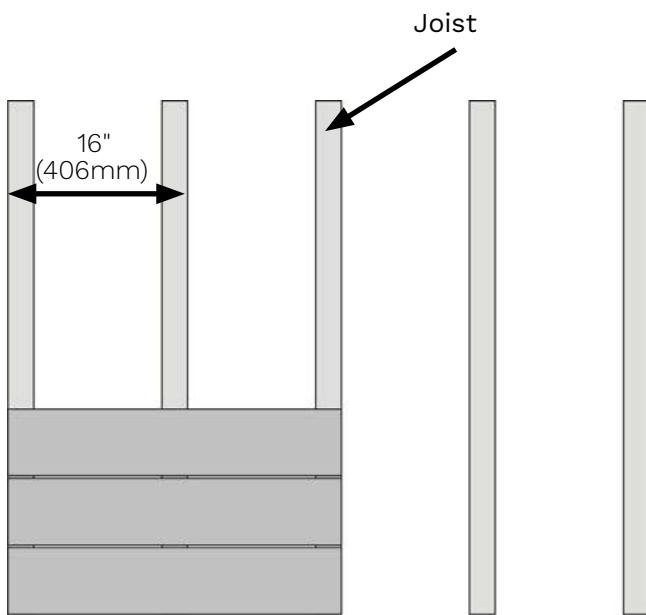
We recommend for the under construction aluminum or pressure treated wood joists. Each cladding board needs to be supported by a joist NO MORE than 16" (406mm) from center to center. Extra care is required in order to provide sufficient joisting in and around obstacles such as windows, fascia's, soffits, guttering, ventilation points etc. Below is an example of the layers that would occur in a typical installation, but a licensed professional should always be consulted prior to any installation.



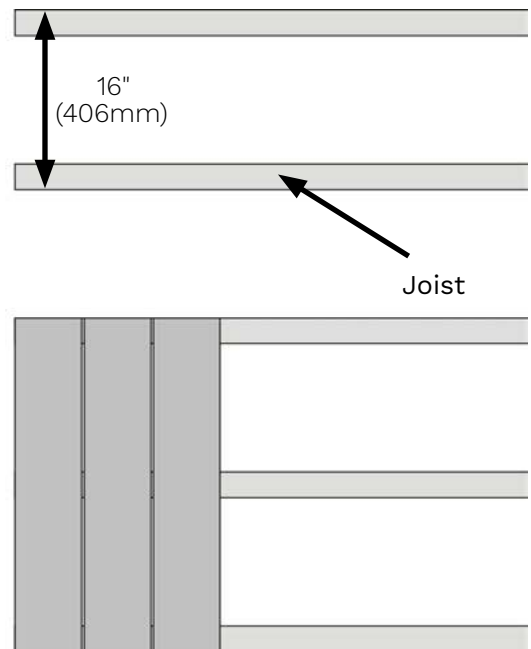
## Joist Installation

A building professional should be consulted regarding vapor barriers and insulation for your project. Where a vapor barrier is to be used, it should be a breathable type and must be positioned behind the joists. The joist needs to have a minimum thickness of 1" (25mm).

Wood joists should be fixed into position at a maximum of 16" (406mm) centers using a suitable A4 Stainless Steel Countersunk Wood/Masonry screw. All joists needs to be flat and leveled against the wall surface use shims if necessary.



**Horizontal Installation**



**Vertical Installation**

## Expansion and Contraction Values

NewTechWood siding boards will experience expansion and contraction with changes in temperature. Expansion and contraction are most significant where extreme temperature changes occur. Fastening the deck planks according to the gapping requirements noted in the following table accommodates for this movement.

### Expansion and Contraction table of values for North America, Canada, Australia and Asia

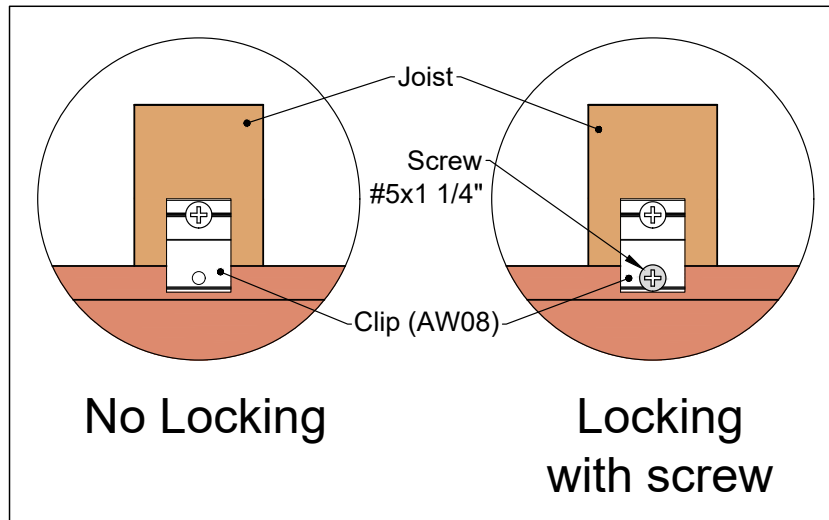
		Length (Feet)								
		3	8	9	10	12	13	16	18	
Installation Temperature (Farhenheit)	<b>32</b>	1/16	2/16	2/16	3/16	3/16	4/16	4/16	5/16	Gap (in)
	<b>41</b>	1/16	2/16	2/16	2/16	3/16	3/16	4/16	4/16	
	<b>50</b>	1/16	2/16	2/16	2/16	2/16	3/16	3/16	3/16	
	<b>59</b>	1/16	1/16	1/16	2/16	2/16	2/16	2/16	3/16	
	<b>68</b>	3/64	1/16	1/16	1/16	1/16	2/16	2/16	2/16	
	<b>77</b>	3/64	1/16	1/16	1/16	1/16	1/16	1/16	1/16	
	<b>86</b>	3/64	3/64	3/64	3/64	3/64	1/16	1/16	1/16	

**Note:** If you are still unsure of what gapping to use, contact the manufacturer and they will give you the correct gapping requirements based on your environment and area.

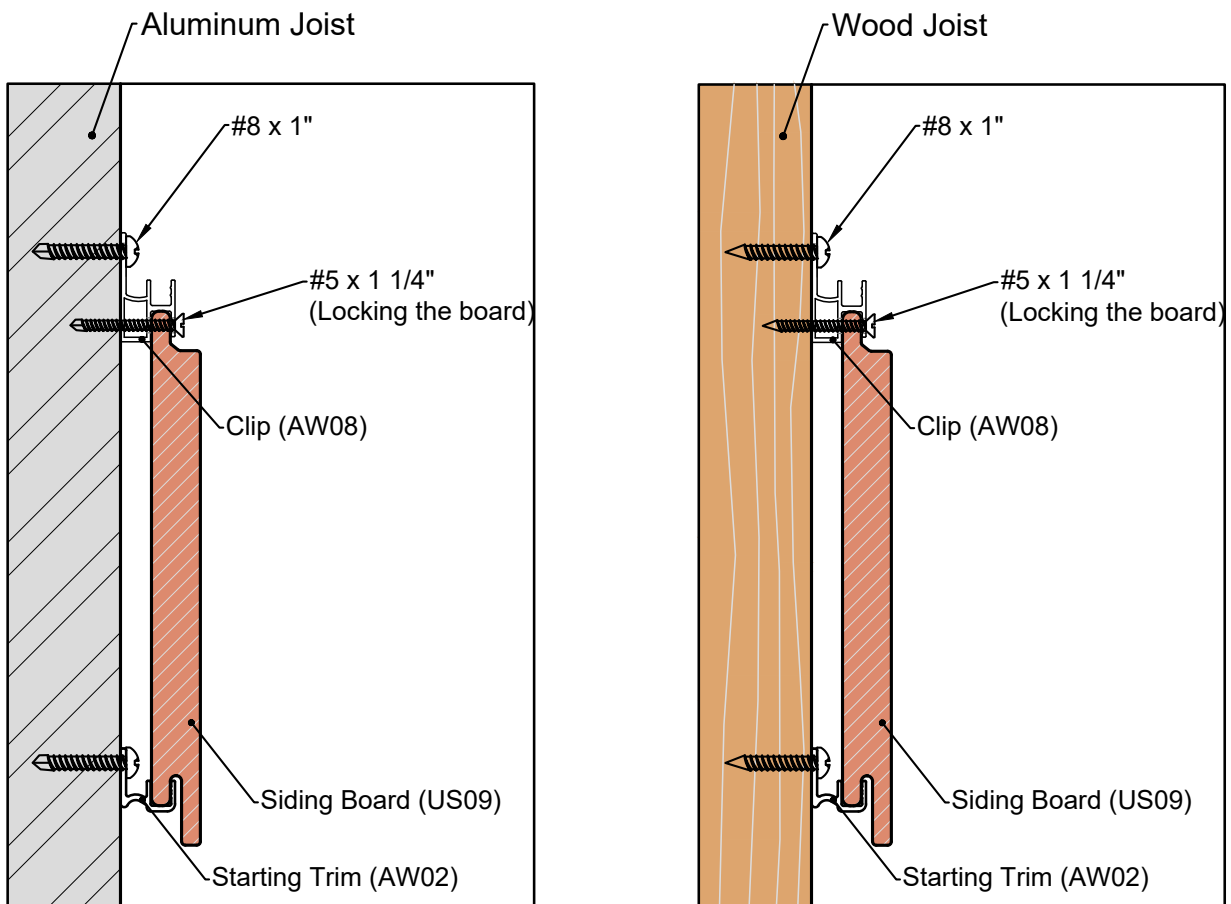
## Locking the Siding Board

Since the composite wood must allow for expansion and contraction due to temperature change, the board must be locked at one fixed point but only one point to allow the remaining board to expand and contract freely. In the case there is a need to lock the board, Clip (AW08) comes with a separate hole.

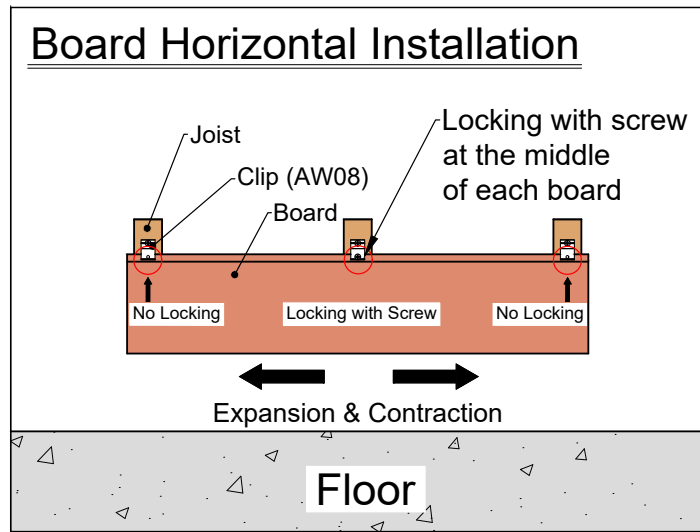
It is important that **DO NOT LOCK** any other clips for the same board.



### - Horizontal Installation -

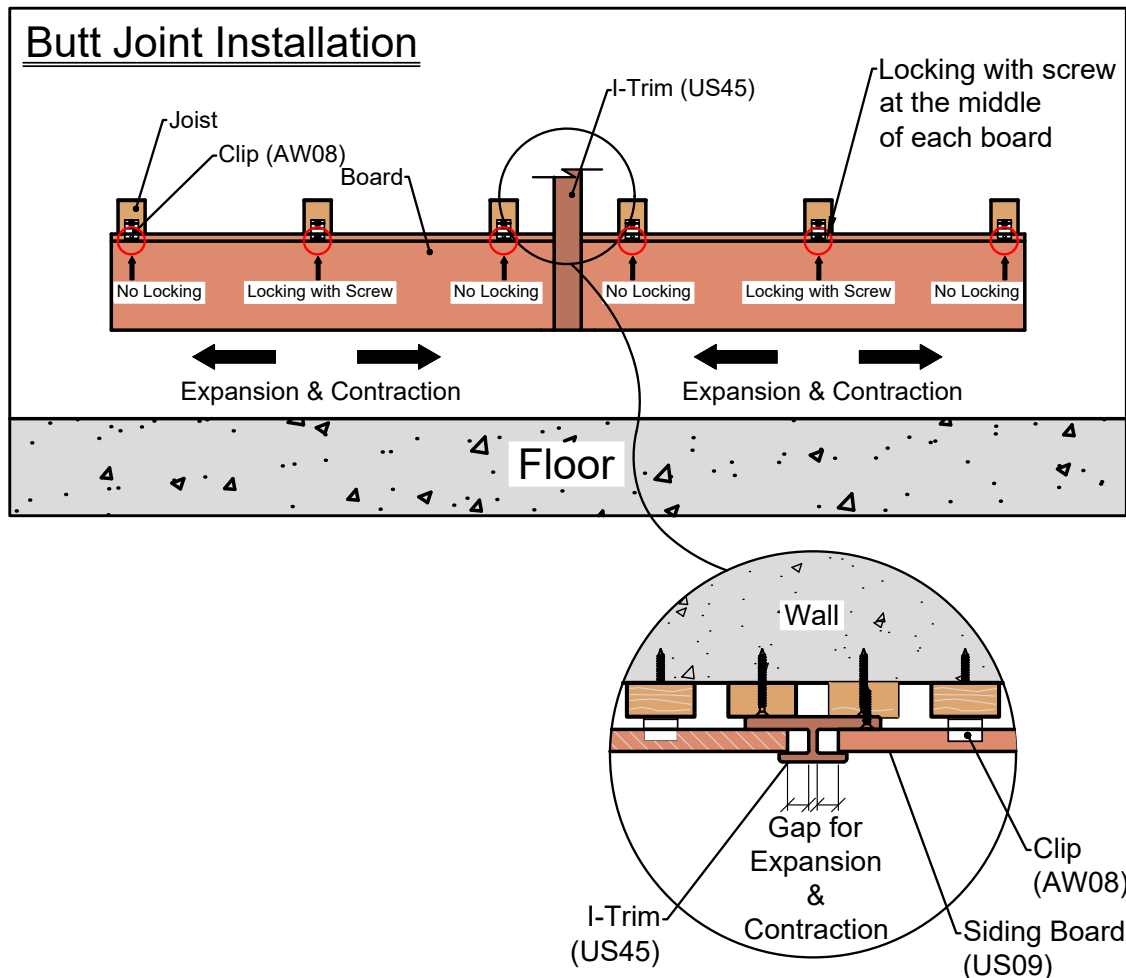


When installing horizontally, it is required to lock the Clip (AW08) at the middle of the board, as shown in **Diagram 1**.



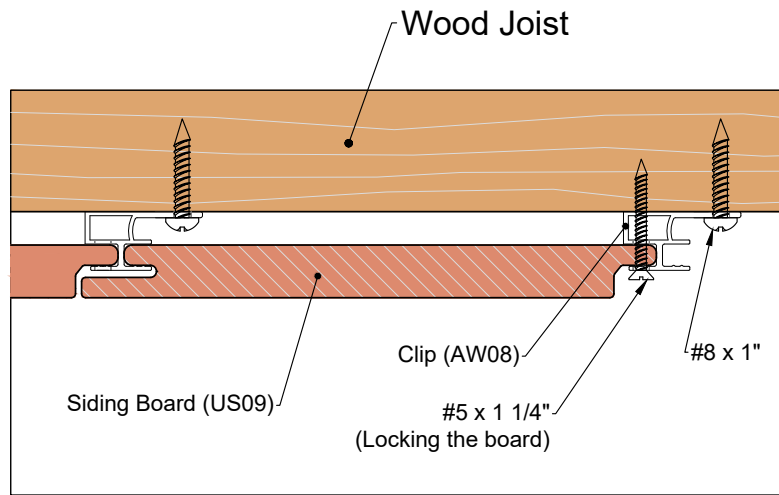
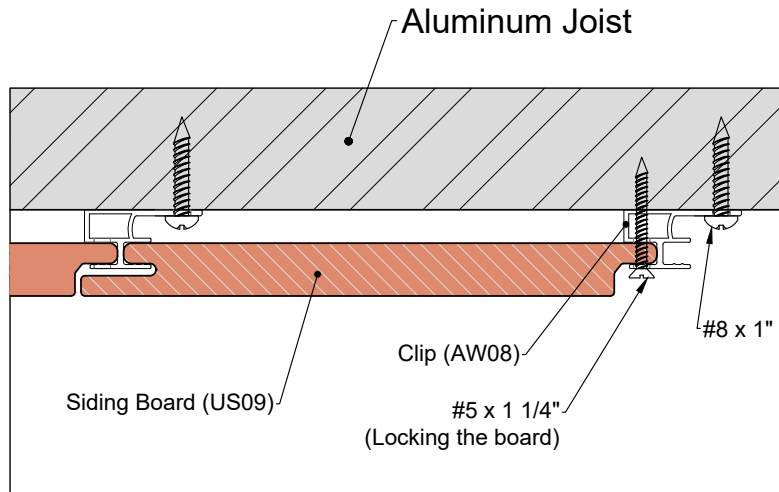
**Diagram 1**

When installing more than one board horizontally, it is recommended to utilize the I-Trim (US45) at each butt joint. It is also required to lock the Clip (AW08) at the middle of each board, as shown in **Diagram 2**.

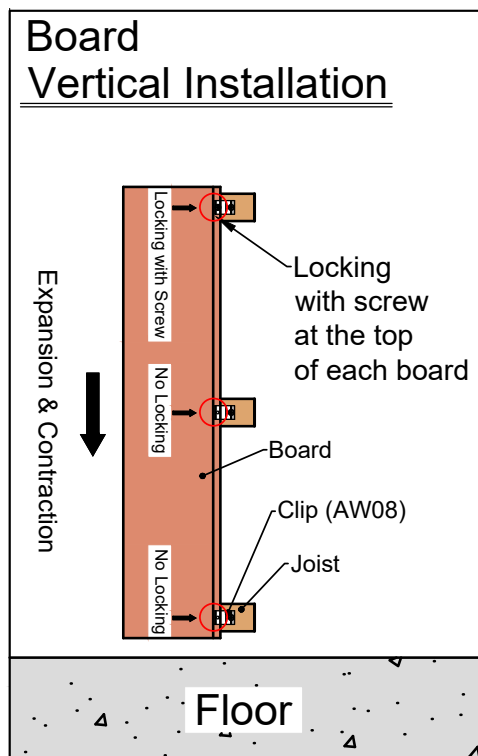


**Diagram 2**

- Vertical Installation -

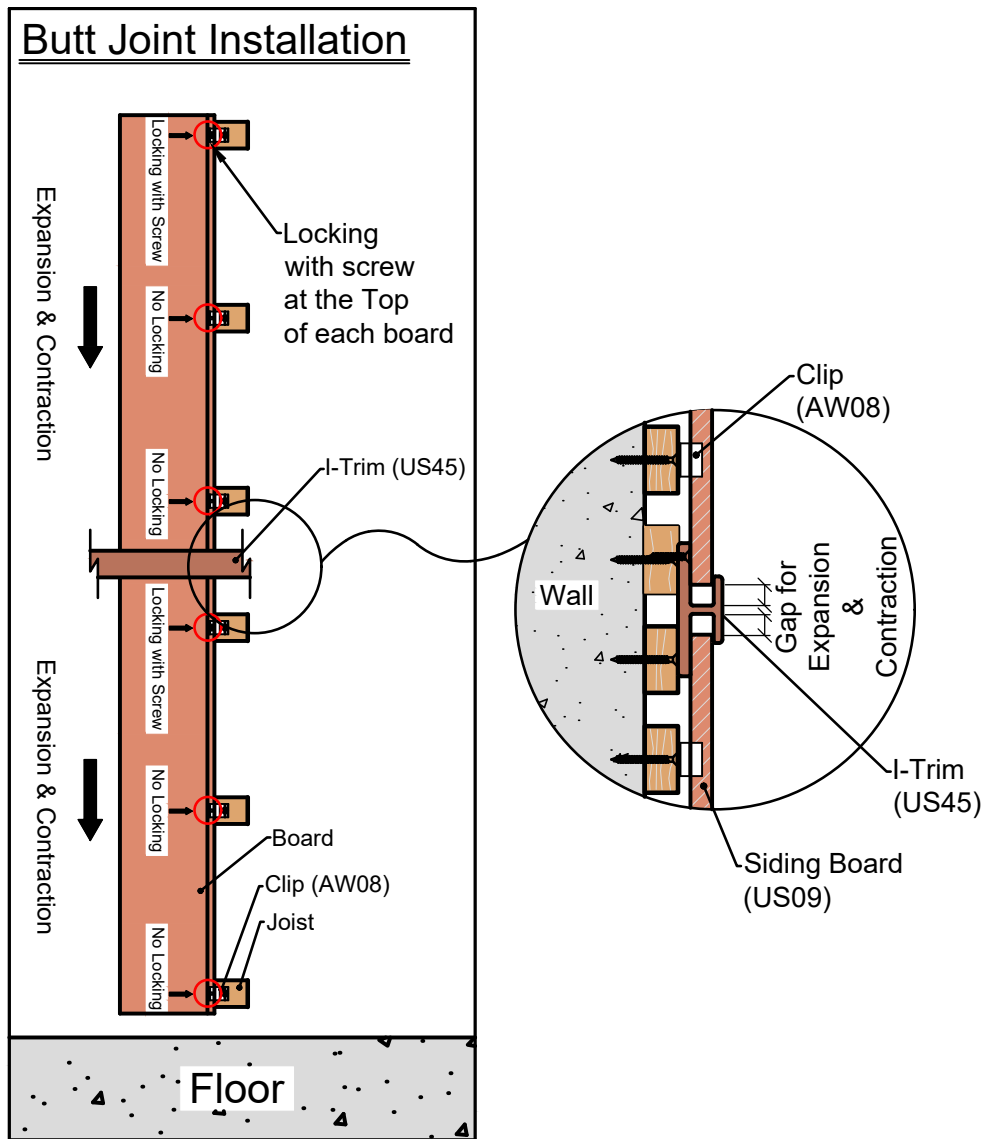


When installing vertically, it is required to lock the Clip (AW08) at the top of the board, as shown in **Diagram 3**.



**Diagram 3**

When installing more than one board vertically, it is recommended to utilize the I-Trim (US45) at each butt joint. It is also required to lock the Clip (AW08) at the top of each board, as shown in **Diagram 4**.



**Diagram 4**



# Siding Vertical Installation

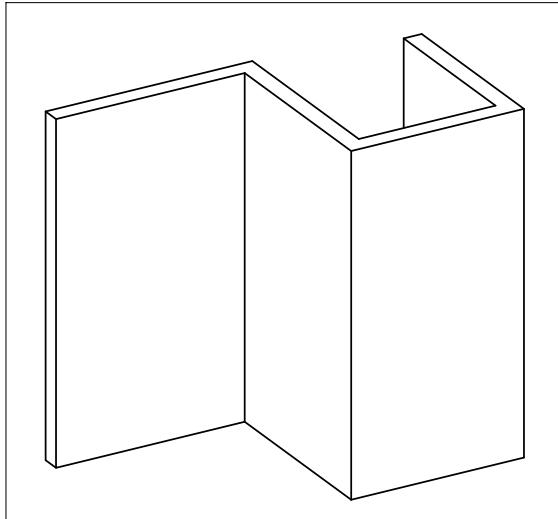
## Framing

The frame needs to be level before installing the Siding boards.

**Note:**

An adequate span between the joists is required to keep the Siding boards from bending. Please review [page 10](#) of this installation guide to see what span is needed.

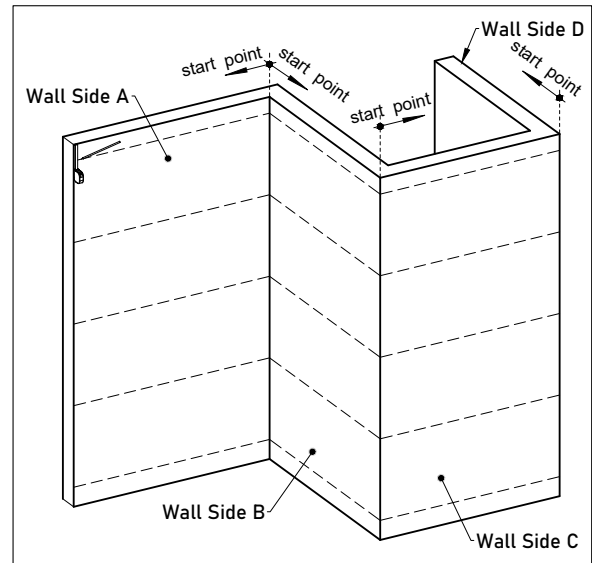
The below diagram shows the wall replicating different scenarios potentially occurring when installing the Siding boards.



**Note:**

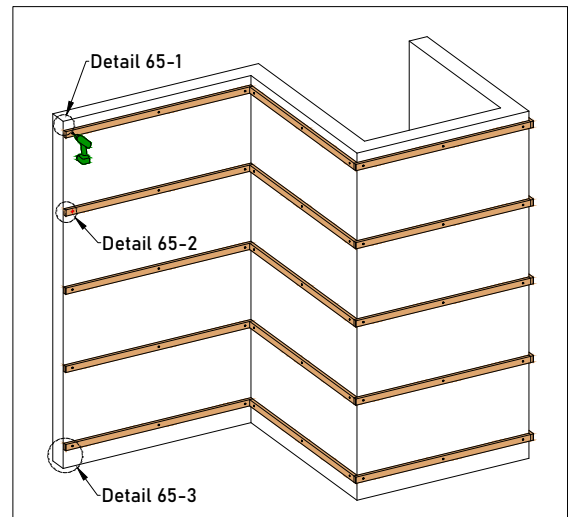
We are using wood joists for this installation. If you are using aluminum joists, please refer to [page 8](#) of this installation guide for the correct recommended screws.

- 1 Measure and chalk the joists according to the span data specified on page 8 of this installation guide, as shown in [Diagram 64](#).



**Diagram 64**

- 2 Fix the joists onto the wall that you intend to install with screws. The distance between the screws should be at least 19 5/8" (500mm) and max to 39 3/8" (1000mm), as shown in [Diagram 65](#).



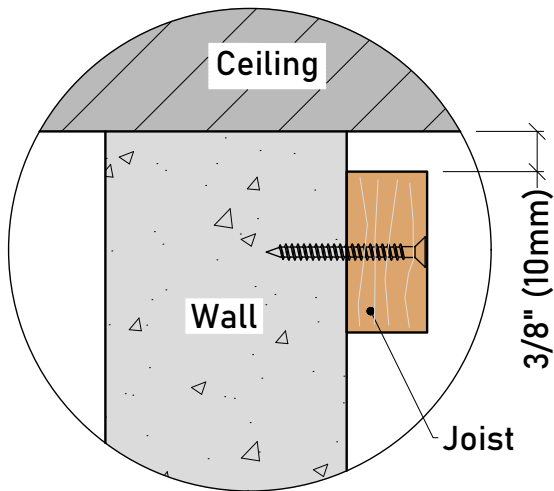
**Diagram 65**

**Note:**

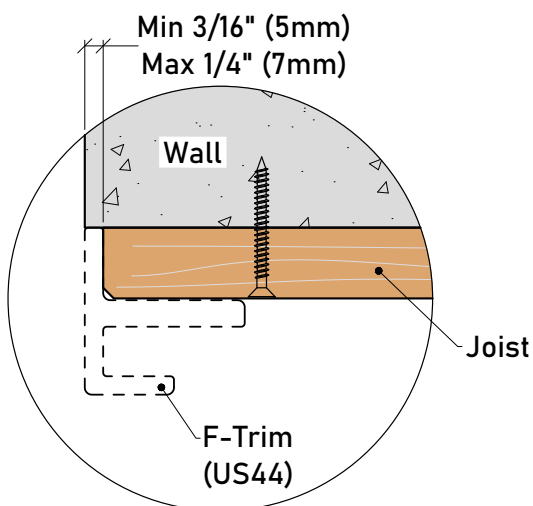
1. A minimum gap of 3/8" (10mm) needs to be left between the upper first joist and ceiling, as shown in *Detail 65-1*.

2. It is recommended to leave a gap from min 3/16" (5mm) and max to 1/4" (7mm) between the wall's outermost edge and the joists, as shown in *Detail 65-2*.

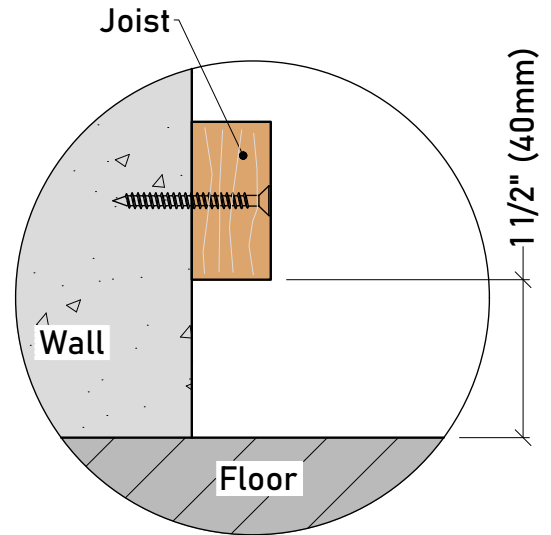
3. A minimum gap of 1 1/2" (40mm) needs to be left between the lowest joist and the floor, as shown in *Detail 65-3*.



**Detail 65-1**



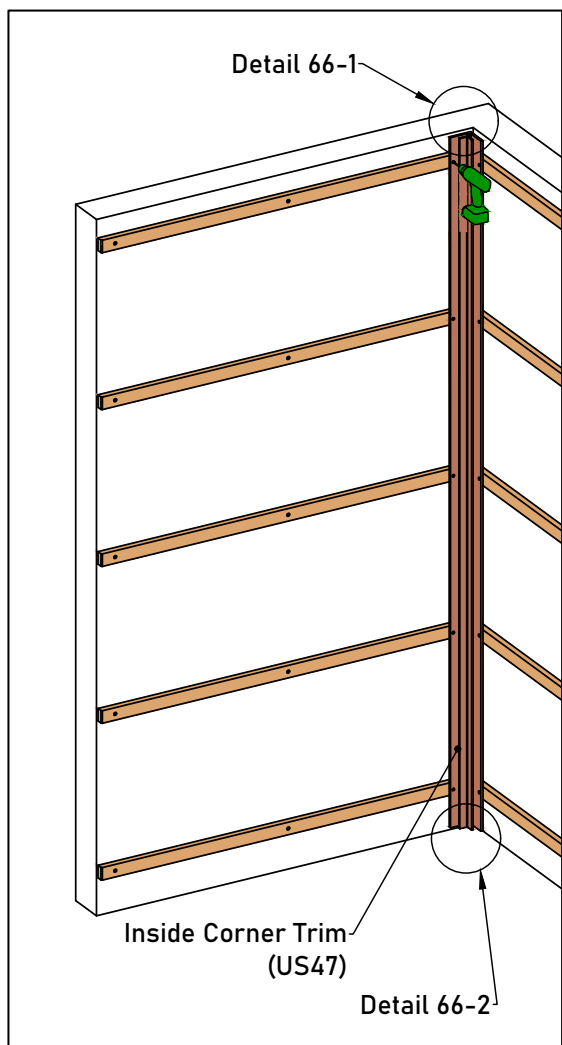
**Detail 65-2**



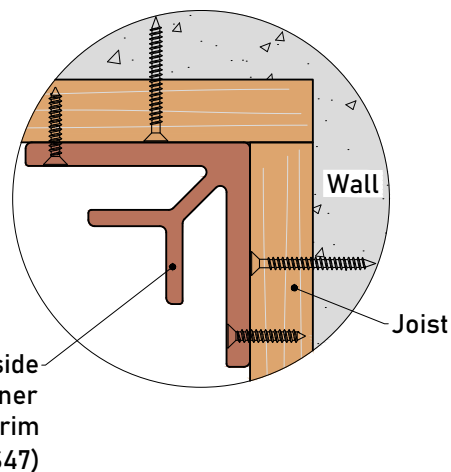
**Detail 65-3**

**3 Wall Side A**  
**(Between the Outermost Edge and the Inside Corner)**

Fasten the Inside Corner Trim (US47) with screws onto the joists. It is recommended to begin the installation from the inside corner, as shown in **Diagram 66** and **Detail 66-1**.



**Diagram 66**

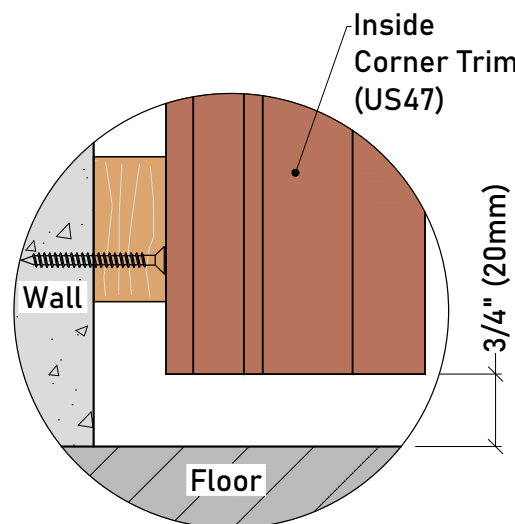


**Detail 66-1**

**Note:**

1. Pre-drill the screw holes for the Inside Corner Trim (US47) before installation.

2. A minimum gap of 3/4" (20mm) needs to be left between the Inside Corner Trim (US47) and the floor, as shown in **Detail 66-2**.



**Detail 66-2**

- 4 Insert the first Siding Board (US09) into the Inside Corner Trim (US47) and fasten it to the joists using Clip (AW08), as shown in **Diagram 67**.

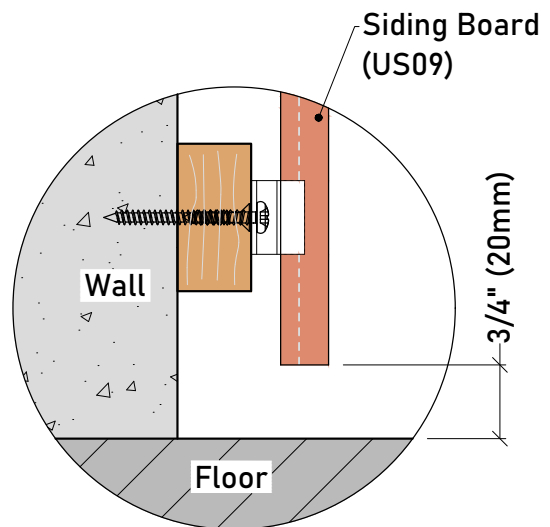
**Note:**

1. Since the composite wood must allow for expansion and contraction due to temperature change, the board must be **locked at one fixed point but only one point** to allow the remaining board to move freely. When installing vertically, it is required to **lock the Clip (AW08) at the top of each board**, as shown in **Diagram 67**.

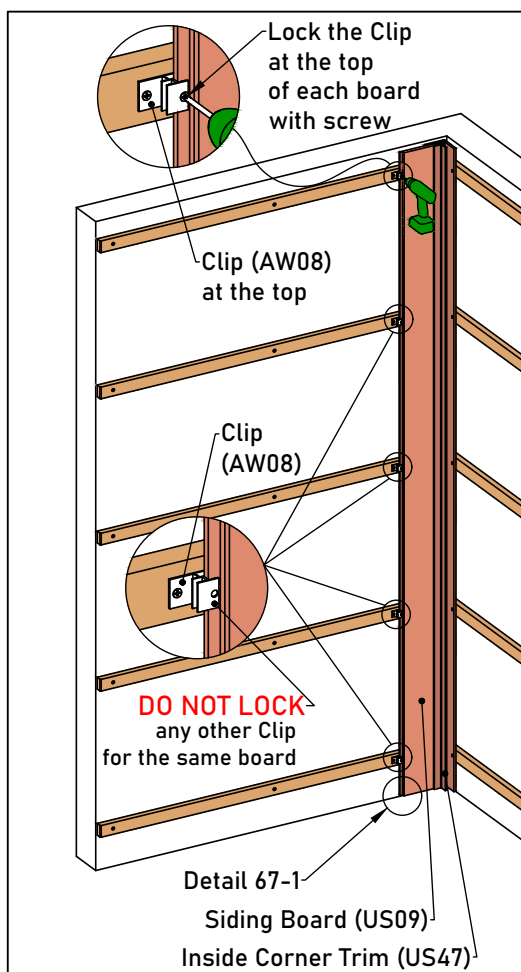
**DO NOT LOCK** any other Clip (AW08) for the same board.

Please review *page 12*, “Locking the Siding Board” of this installation guide for further information.

2. The distance between the Siding Board (US09) and the floor should be at least 3/4" (20mm), as shown in **Detail 67-1**.

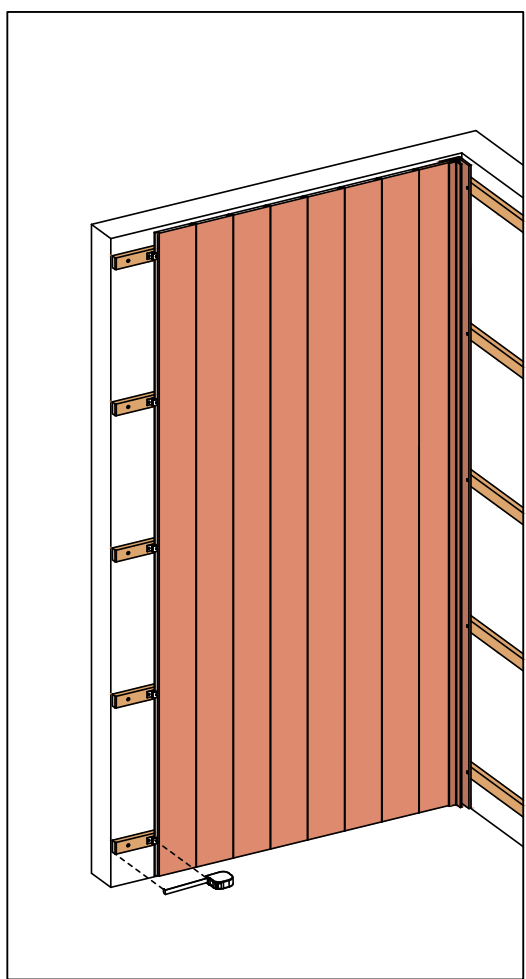


**Detail 67-1**

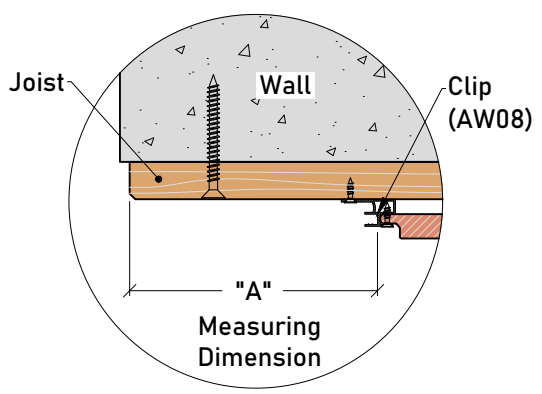


**Diagram 67**

- 5 When you are at the Siding's last board, measure the distance between the joist's end and the Clip (AW08), as shown in **Diagram 68** and **Detail 68-1**.

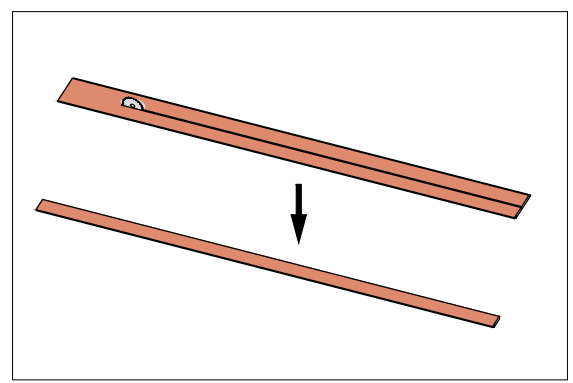


**Diagram 68**

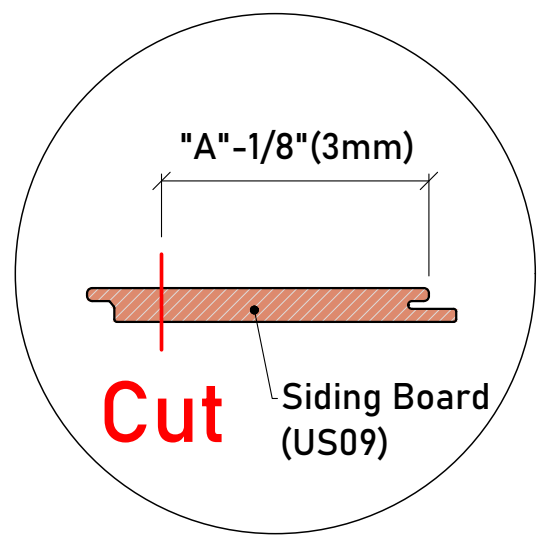


**Detail 68-1**

- 6 Cut the Siding Board (US09) according to the measured length, as shown in **Diagram 69** and **Detail 69-1**.

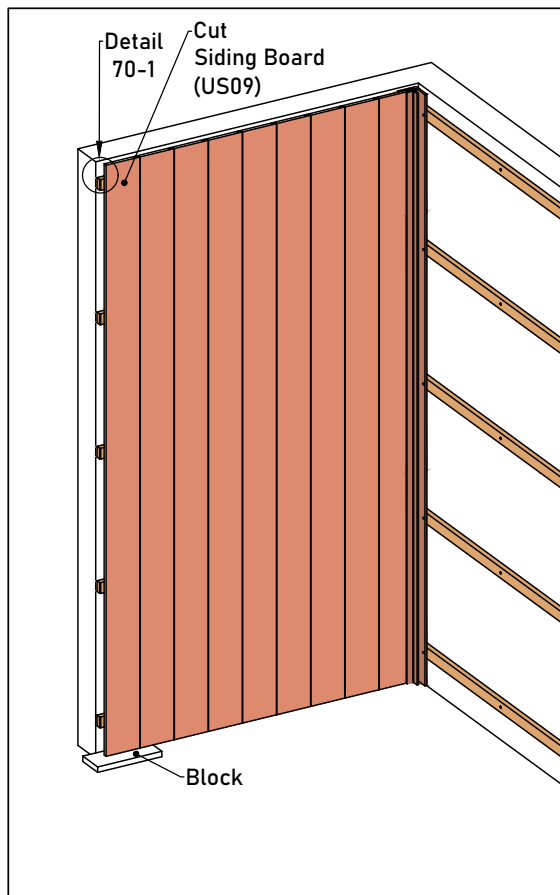


**Diagram 69**

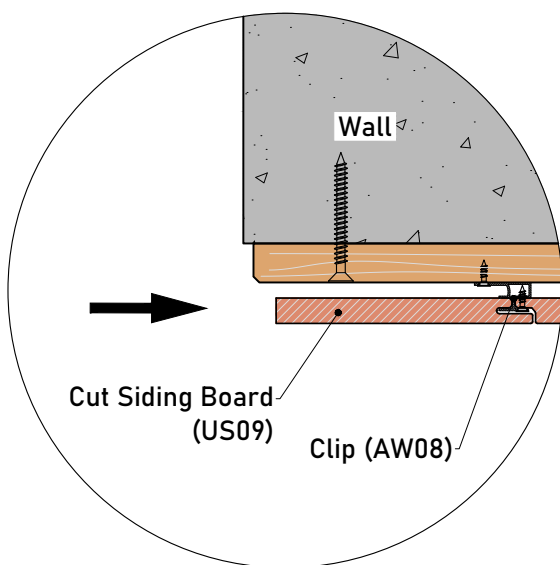


**Detail 69-1**

- 7 Put the cut Siding Board (US09) in place and put a block under it to guarantee the board is at the same level as the other boards, as shown in **Diagram 70** and **Detail 70-1**.

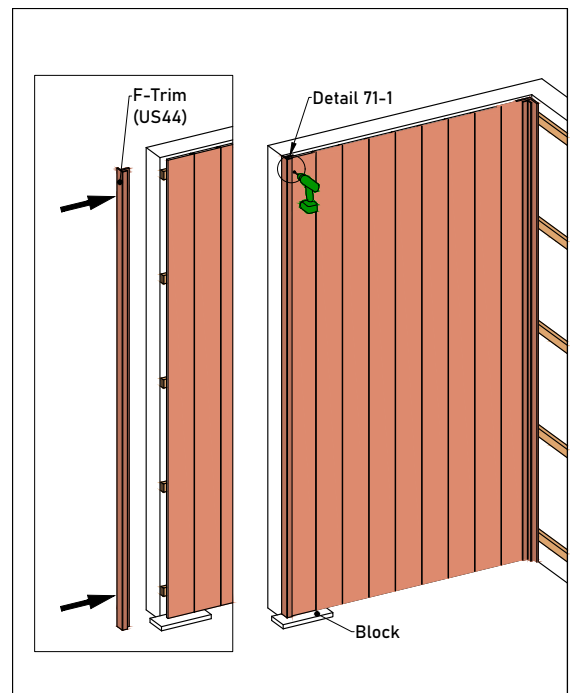


**Diagram 70**

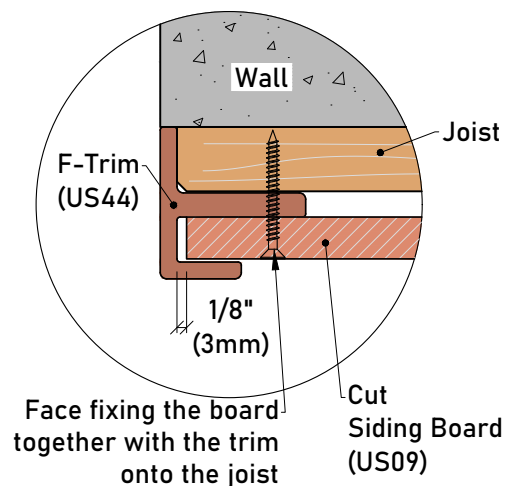


**Detail 70-1**

- 8 Insert the F-Trim (US44) in place. On the top of the cut Siding Board (US09), face fix it together with the F-Trim (US44) onto the joist, as shown in **Diagram 71** and **Detail 71-1**.

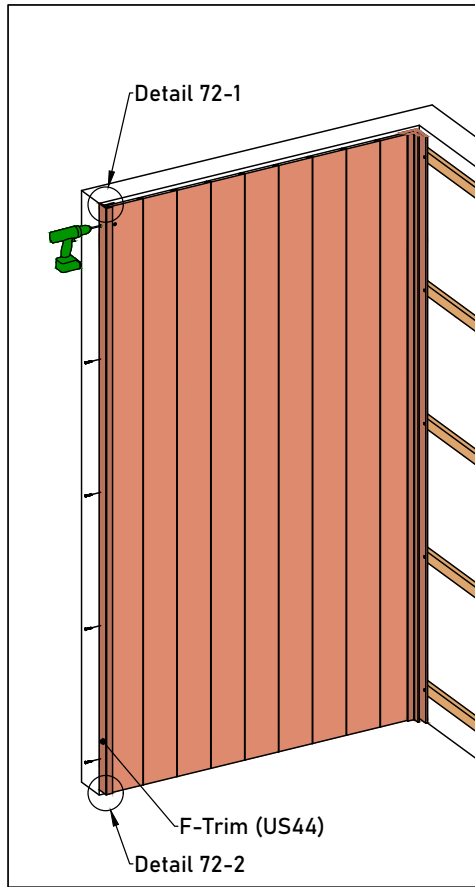


**Diagram 71**

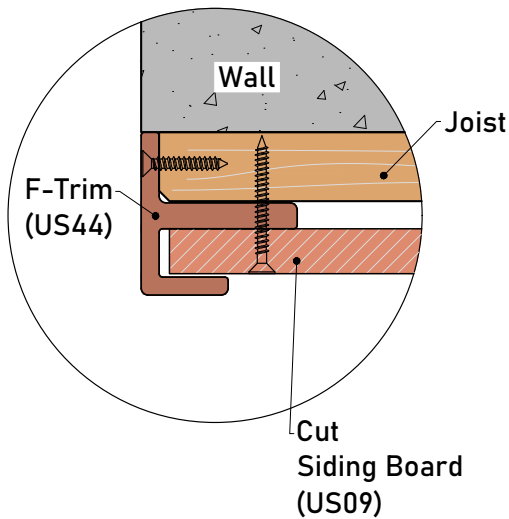


**Detail 71-1**

- 9 Secure the F-Trim (US44) onto the joist with screws, as shown in **Diagram 72** and **Detail 72-1**.



**Diagram 72**

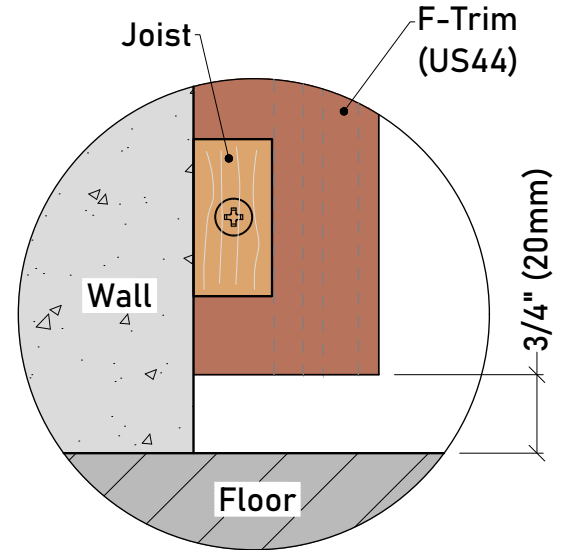


**Detail 72-1**

**Note:**

1. Pre-drill the screw holes for the F-Trim (US44) before installation.

2. A minimum gap of 3/4" (20mm) needs to be left between the F-Trim (US44) and the floor, as shown in **Detail 72-2**.



**Detail 72-2**



**10 Wall Side B**  
**(Between the Inside Corner and the Outside Corner)**

It is recommended to begin the siding board installation from the inside corner. Insert the first Siding Board (US09) into the Inside Corner Trim (US47) and fasten it to the joist with Clip (AW08), as shown in **Diagram 73** and **Detail 73-1**.

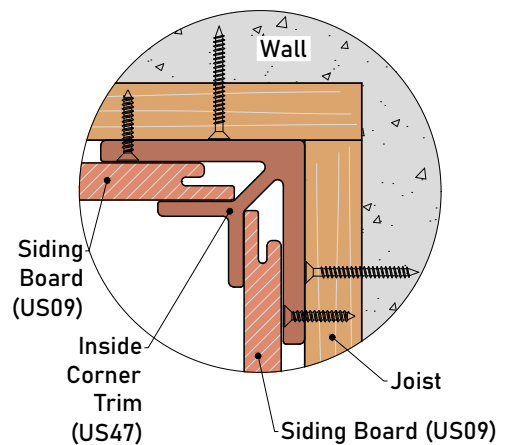
**Note:**

**1. Since the composite wood must allow for expansion and contraction due to temperature change, the board must be locked at one fixed point but only one point to allow the remaining board to move freely. When installing vertically, it is required to lock the Clip (AW08) at the top of each board, as shown in Diagram 73.**

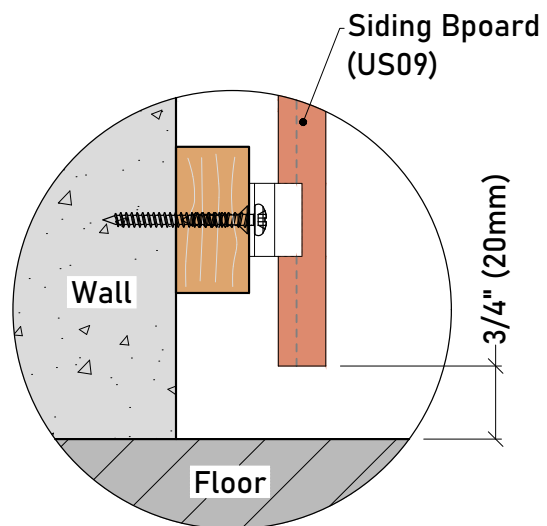
**DO NOT LOCK** any other Clip (AW08) for the same board.

Please review [page 12](#), “Locking the Siding Board” of this installation guide for further information.

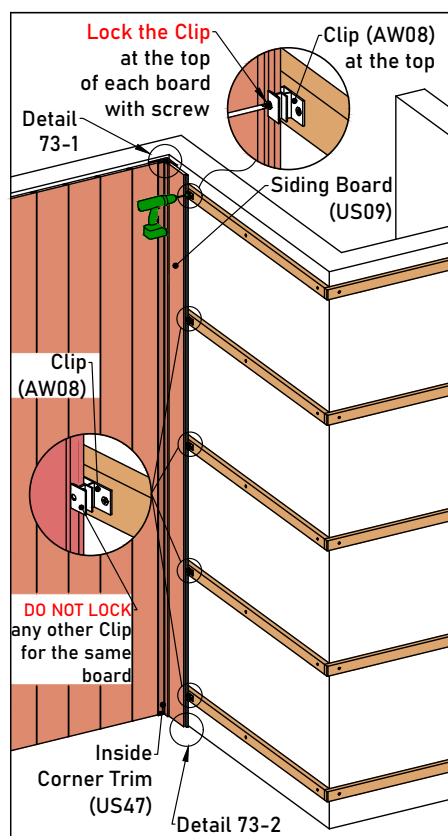
**2. The distance between the Siding Board (US09) and the floor should be at least 3/4" (20mm), as shown in Detail 73-2.**



**Detail 73-1**

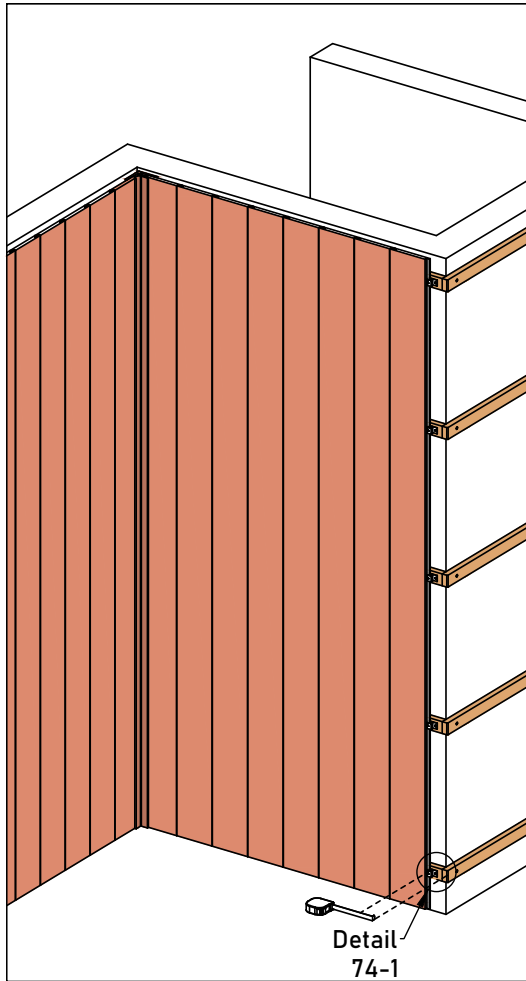


**Detail 73-2**

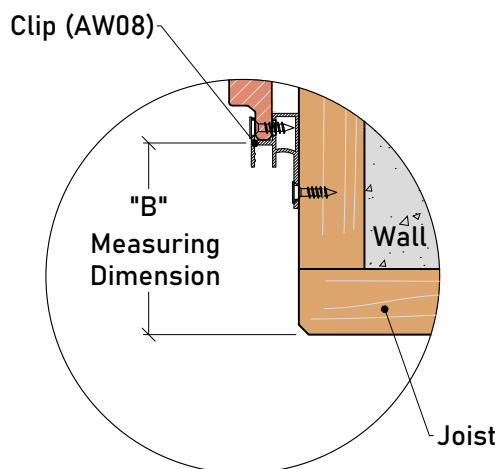


**Diagram 73**

- 11 When you are at the Siding's last board, measure the distance between the joist and the Clip (AW08), as shown in **Diagram 74** and **Detail 74-1**.

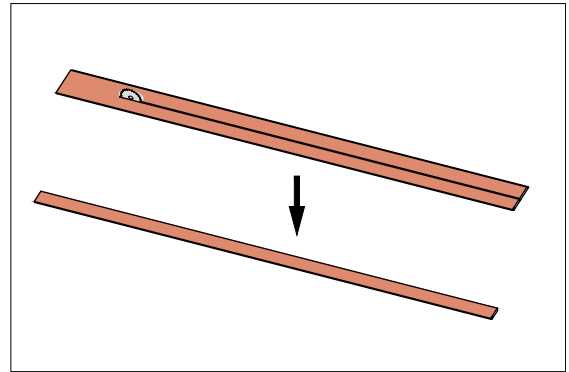


**Diagram 74**

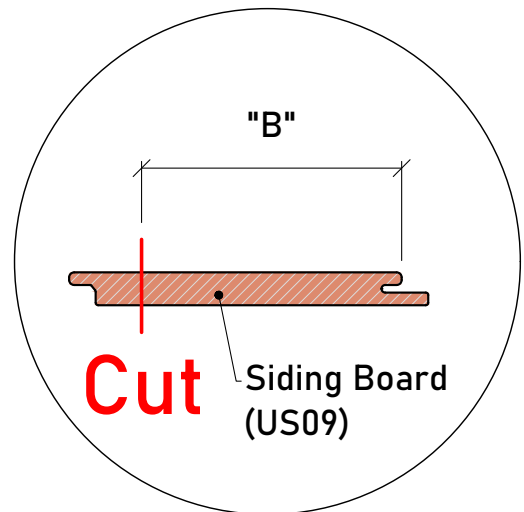


**Detail 74-1**

- 12 Cut the Siding Board (US09) according to the measured length, as shown in **Diagram 75** and **Detail 75-1**.

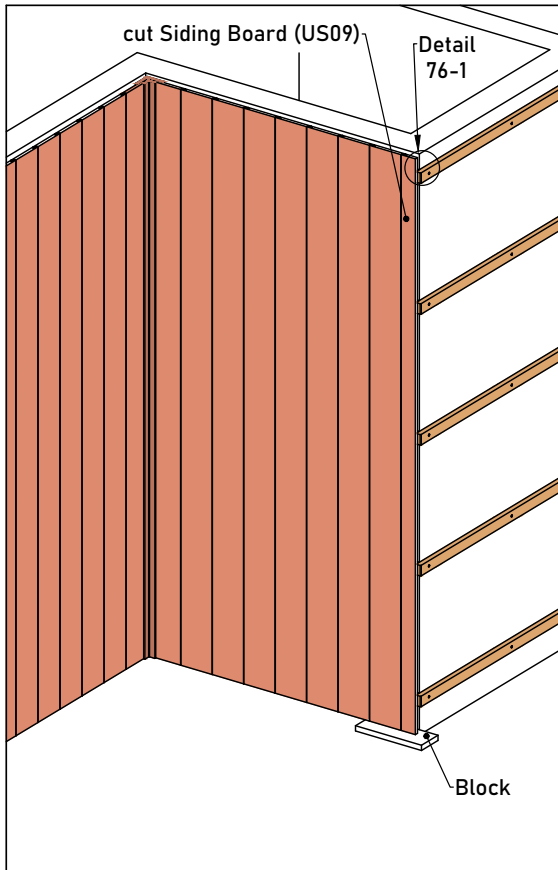


**Diagram 75**

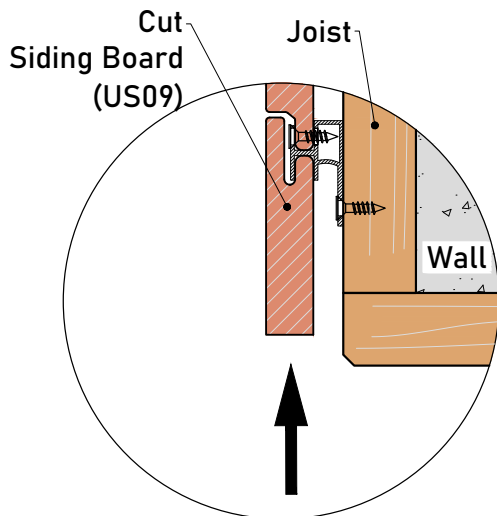


**Detail 75-1**

- 13 Put the cut Siding Board (US09) in place and put a block under it to guarantee the board is at the same level as the other boards, as shown in **Diagram 76** and **Detail 76-1**.

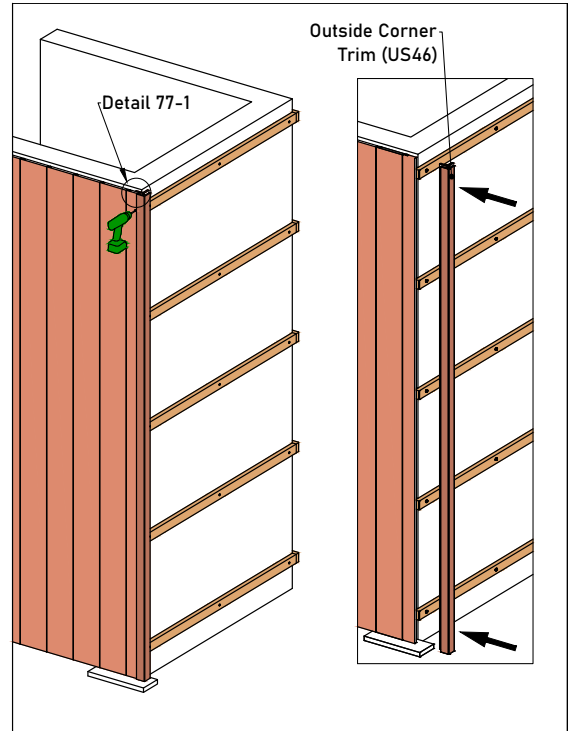


**Diagram 76**

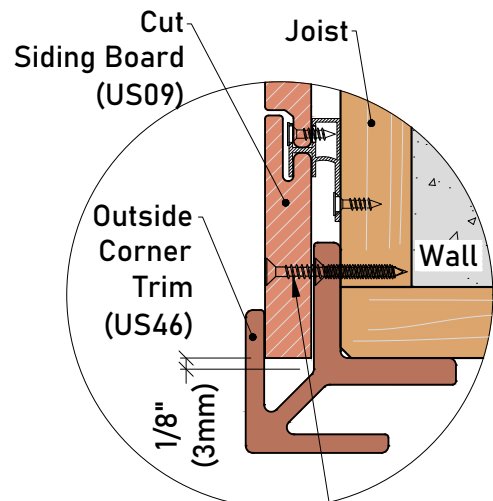


**Detail 76-1**

- 14 Insert the Outside Corner Trim (US46) in place. On the top of the cut Siding Board (US09), face fix it together with the Outside Corner Trim (US46) onto the joist, as shown in **Diagram 77** and **Detail 77-1**.



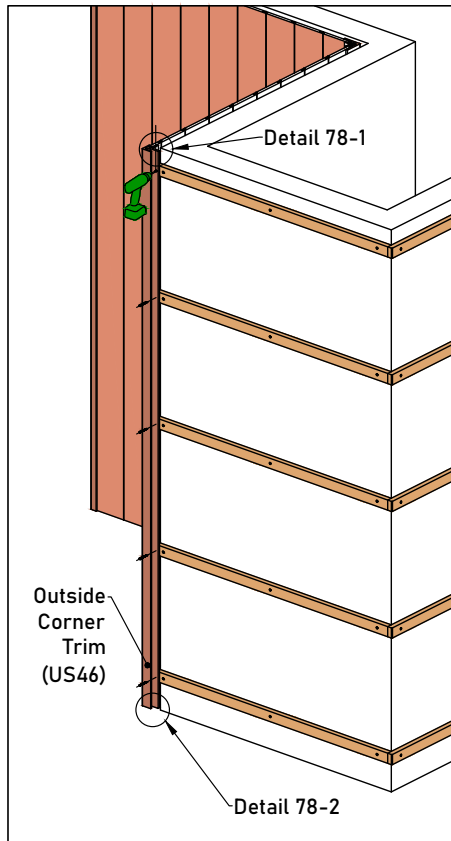
**Diagram 77**



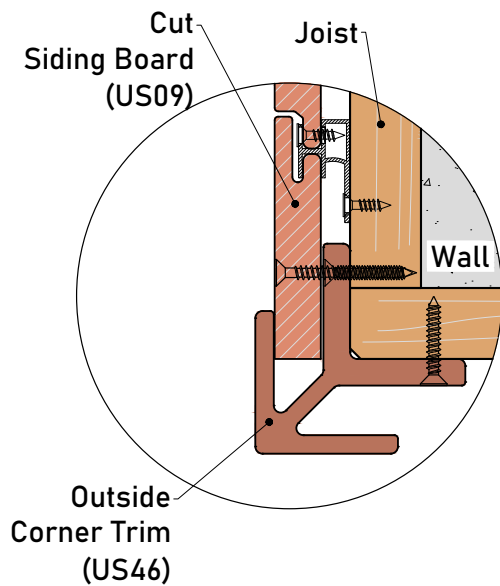
Face fixing the board together with the trim onto the joist

**Detail 77-1**

- 15** Secure the Outside Corner Trim (US46) onto the joists with screws, as shown in **Diagram 78** and **Detail 78-1**.



**Diagram 78**

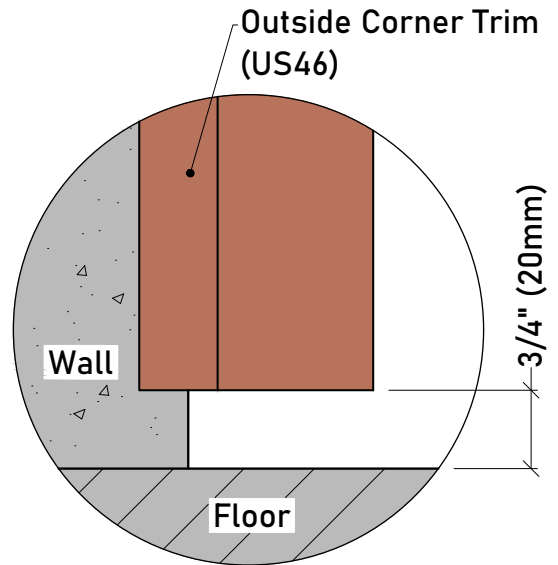


**Detail 78-1**

**Note:**

**1. Pre-drill the holes on the Outside Corner Trim (US46) before installation.**

**2. A minimum gap of 3/4" (20mm) needs to be left between the Outside Corner Trim (US46) and the floor, as shown in **Detail 78-2**.**



**Detail 78-2**

## 16 Wall Side C (Between the Outside Corners)

Insert the first Siding Board (US09) into the Outside Corner Trim (US46) and fasten it to the joist with Clip (AW08), as shown in **Diagram 79** and **Detail 79-1**.

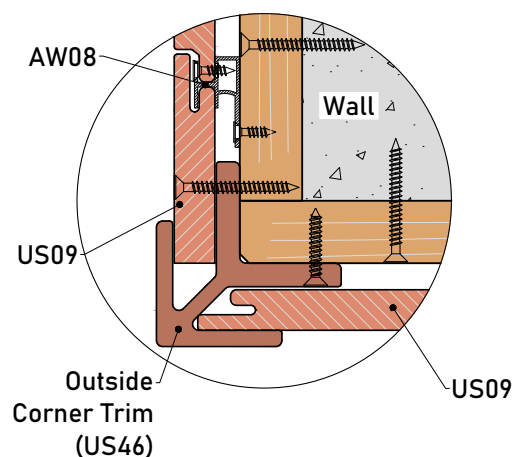
### Note:

1. Since the composite wood must allow for expansion and contraction due to temperature change, the board must be **locked at one fixed point but only one point** to allow the remaining board to move freely. When installing vertically, it is required to lock **the Clip (AW08) at the top of each board**, as shown in **Diagram 79**.

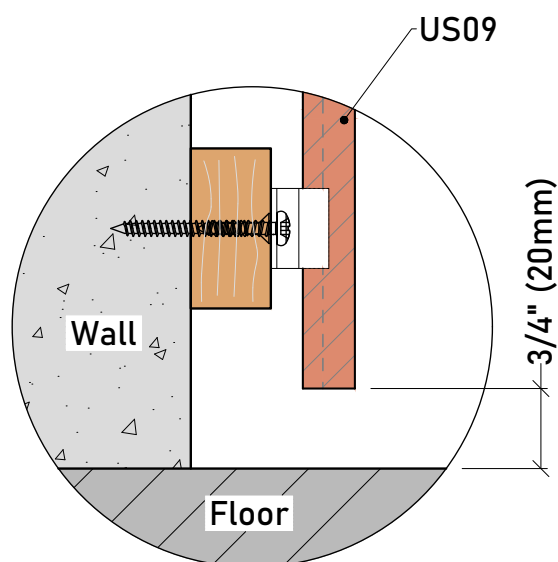
**DO NOT LOCK** any other Clip (AW08) for the same board.

Please review **page 12**, “Locking the Siding Board” of this installation guide for further information.

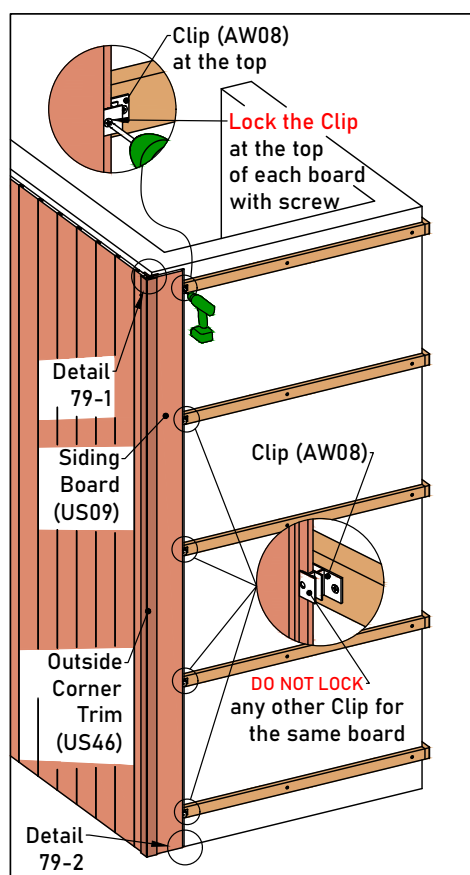
2. The distance between the Siding Board (US09) and the floor should be at least **3/4" (20mm)**, as shown in **Detail 79-2**.



**Detail 79-1**

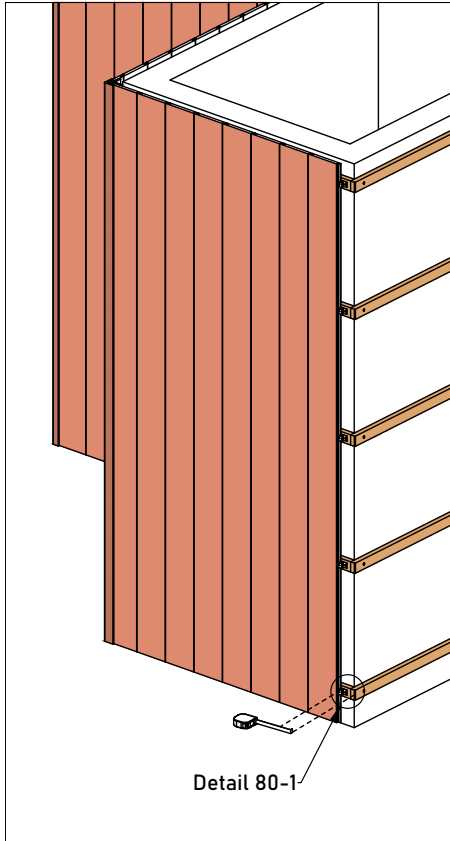


**Detail 79-2**

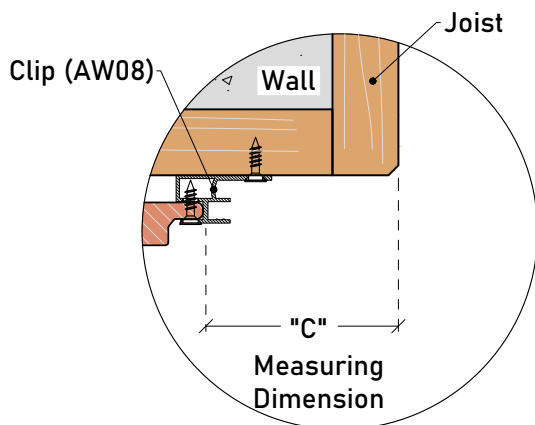


**Diagram 79**

- 17 When you are on the Siding's last board, measure the distance between the Outside Corner Trim (US46) and the Clip (AW08), as shown in **Diagram 80** and **Detail 80-1**.

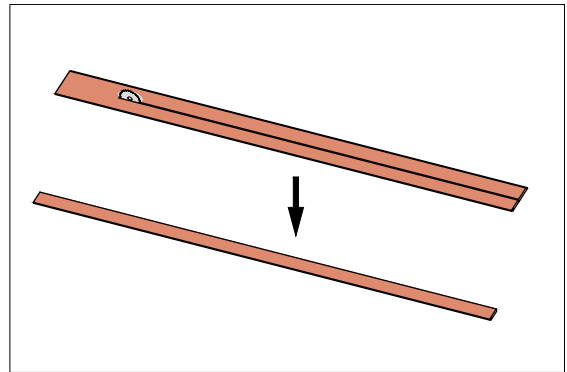


**Diagram 80**

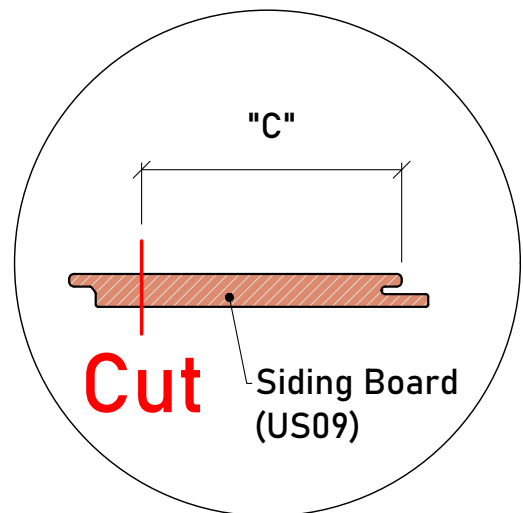


**Detail 80-1**

- 18 Cut the Siding Board (US09) according to the measured length, as shown in **Diagram 81** and **Detail 81-1**.

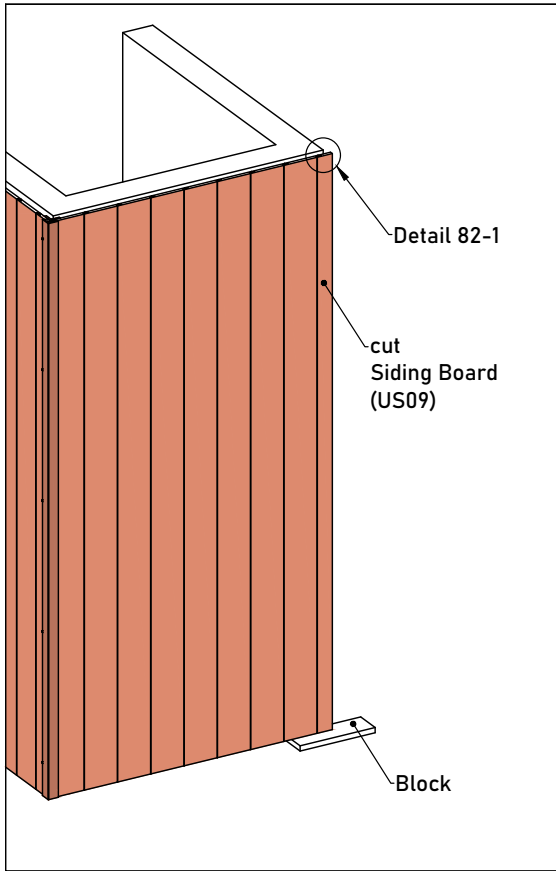


**Diagram 81**

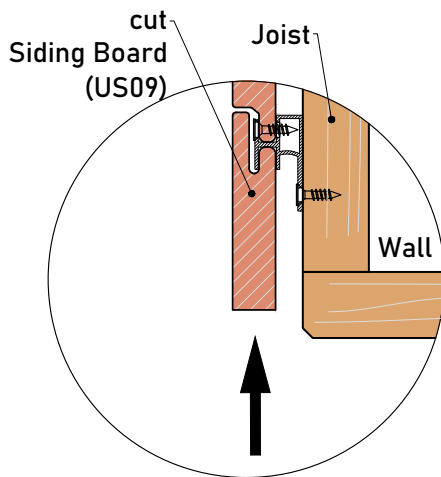


**Detail 81-1**

- 19 Put the cut Siding Board (US09) in place and put a block under it to guarantee the board is at the same level as the other boards, as shown in **Diagram 82** and **Detail 82-1**.

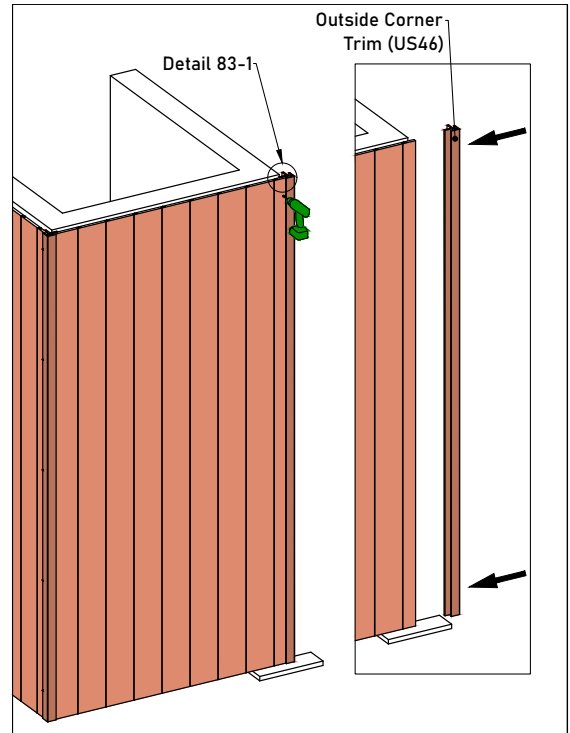


**Diagram 82**

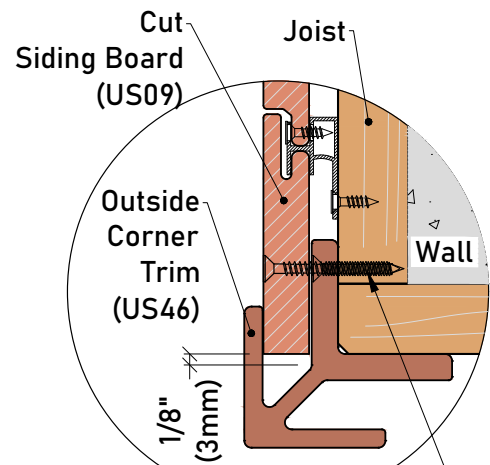


**Detail 82-1**

- 20 Insert the Outside Corner Trim (US46) in place. On the top of the cut Siding Board (US09), face fix it together with the Outside Corner Trim (US46) onto the joist, as shown in **Diagram 83** and **Detail 83-1**.



**Diagram 83**

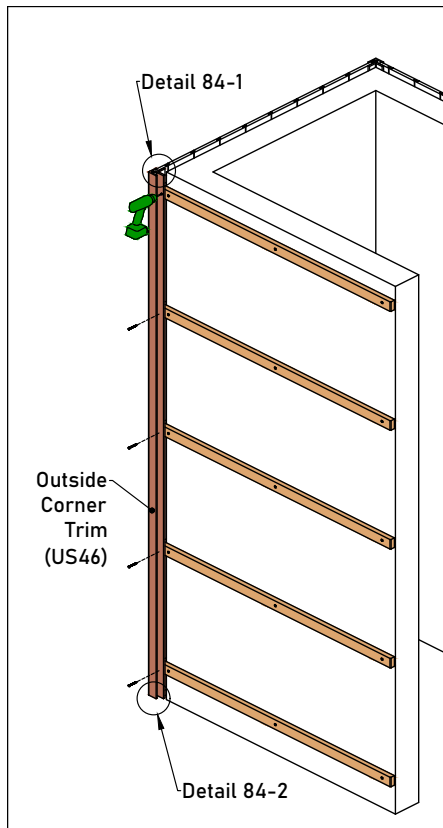


Face fixing the board together with the trim onto the joist

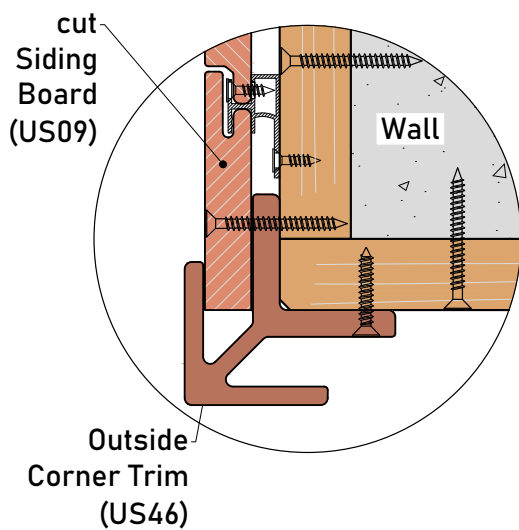
**Detail 83-1**



- 21** Secure the Outside Corner Trim (US46) onto the joists with screws, as shown in **Diagram 84** and **Detail 84-1**.



**Diagram 84**

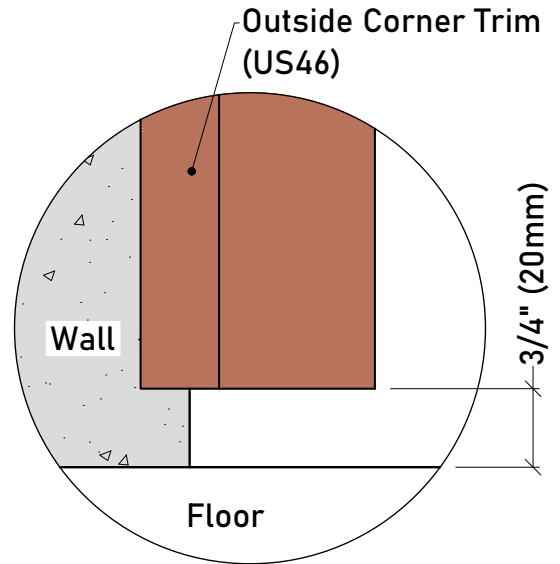


**Detail 84-1**

**Note:**

**1. Pre-drill the holes on the Outside Corner Trim (US46) before installation.**

**2. A minimum gap of 3/4" (20mm) needs to be left between the Outside Corner Trim (US46) and the floor, as shown in **Detail 84-2**.**



**Detail 84-2**

**22 Wall Side D**  
**(Between the Outside Corner and the Outermost Edge)**

Insert the first Siding Board (US09) into the Outside Corner Trim (US46) and fasten it to the joist with Clip (AW08), as shown in **Diagram 85** and **Detail 85-1**.

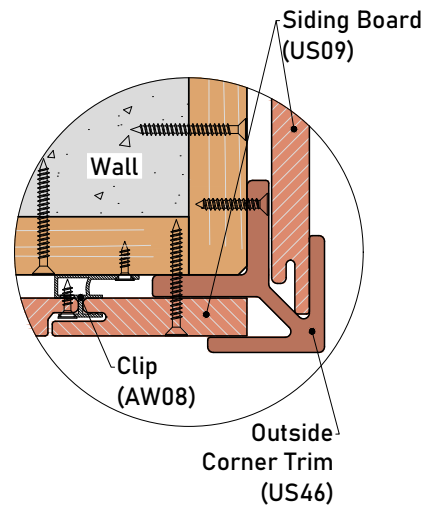
**Note:**

1. Since the composite wood must allow for expansion and contraction due to temperature change, the board must be **locked at one fixed point but only one point** to allow the remaining board to move freely. When installing vertically, it is required to **lock the Clip (AW08) at the top of each board**, as shown in **Diagram 85**.

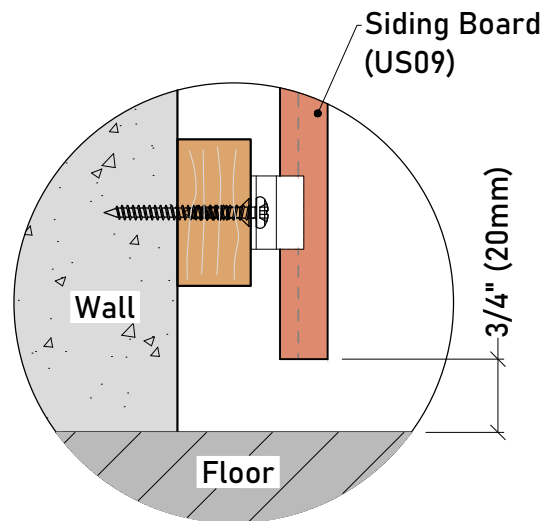
**DO NOT LOCK** any other Clip (AW08) for the same board.

Please review **page 12**, "Locking the Siding Board" of this installation guide for further information.

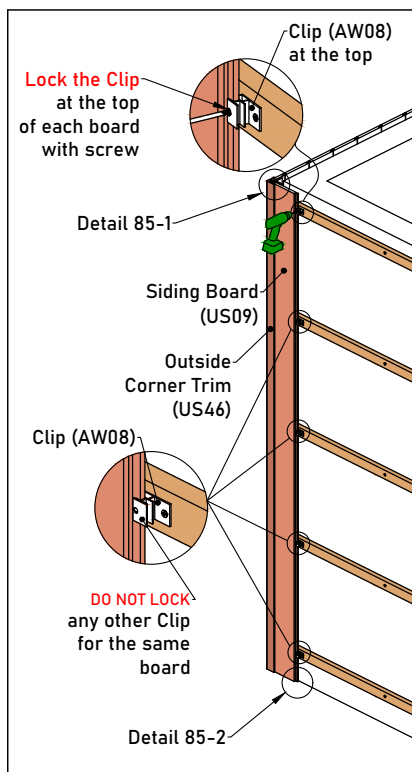
2. The distance between the Siding Board (US09) and the floor should be at least **3/4" (20mm)**, as shown in **Detail 85-2**.



**Detail 85-1**

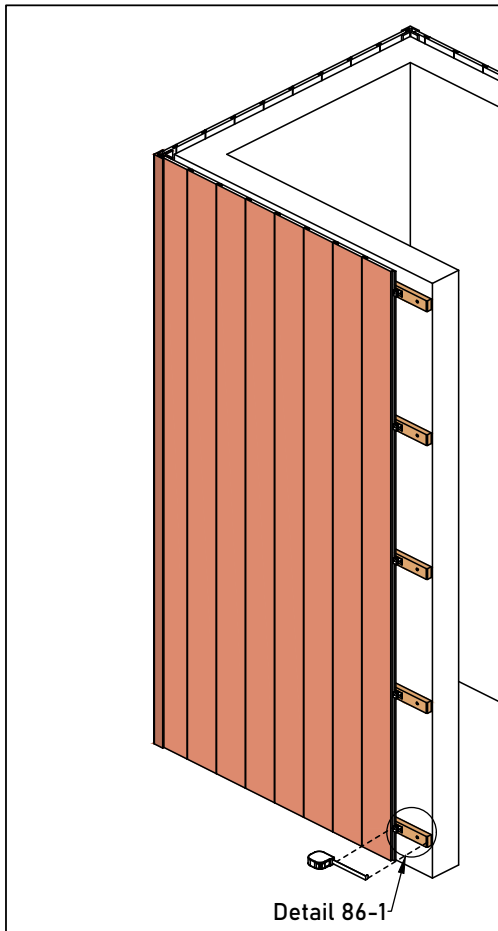


**Detail 85-2**

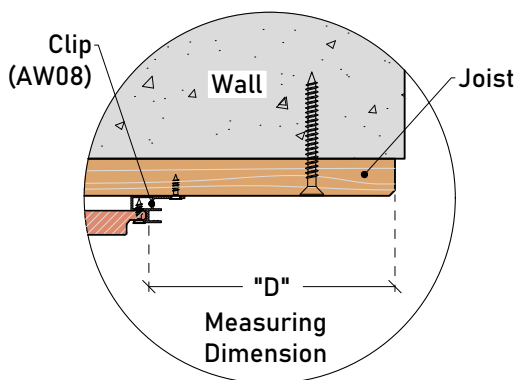


**Diagram 85**

- 23 When you are at the Siding's last board, measure the distance between the joist and the Clip (AW08), as shown in **Diagram 86** and **Detail 86-1**.

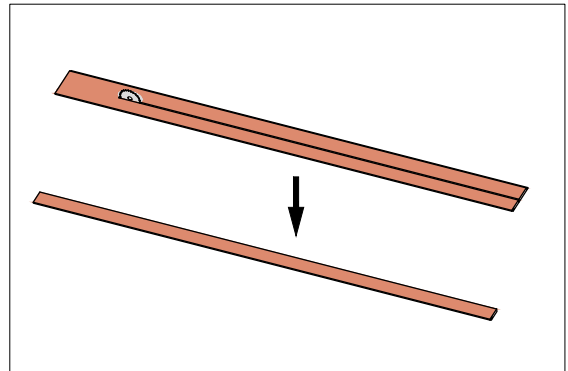


**Diagram 86**

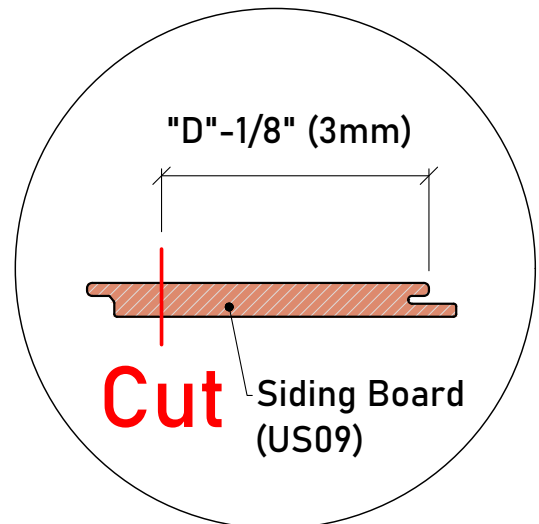


**Detail 86-1**

- 24 Cut the Siding Board (US09) according to the measured length, as shown in **Diagram 87** and **Detail 87-1**.

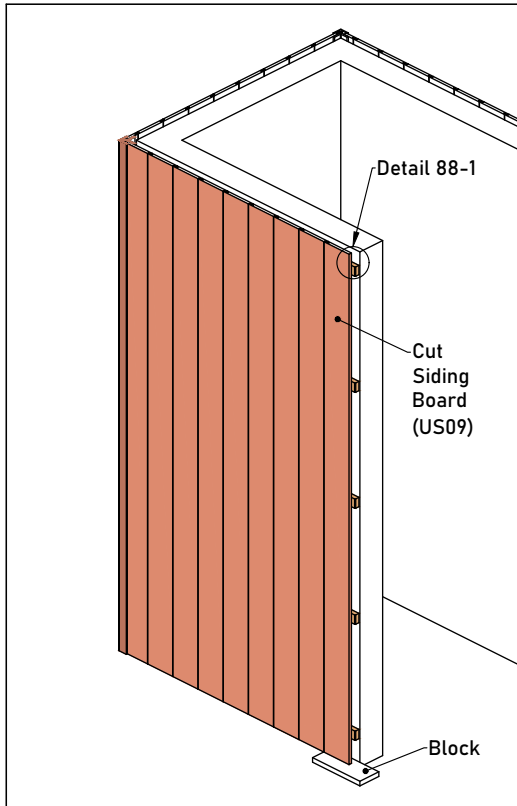


**Diagram 87**

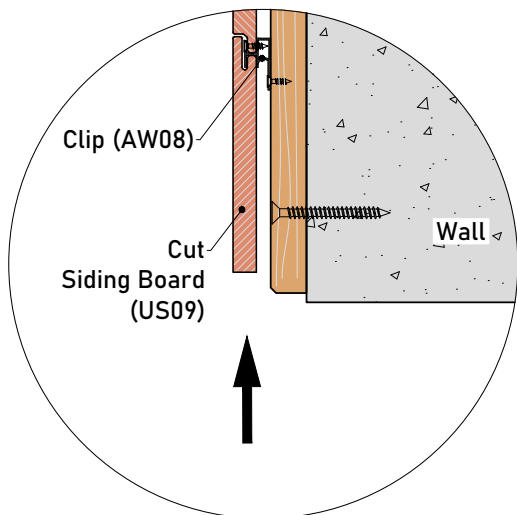


**Detail 87-1**

- 25 Put the cut Siding Board (US09) in place and put a block under it to guarantee the board is at the same level as the other boards, as shown in **Diagram 88** and **Detail 88-1**.

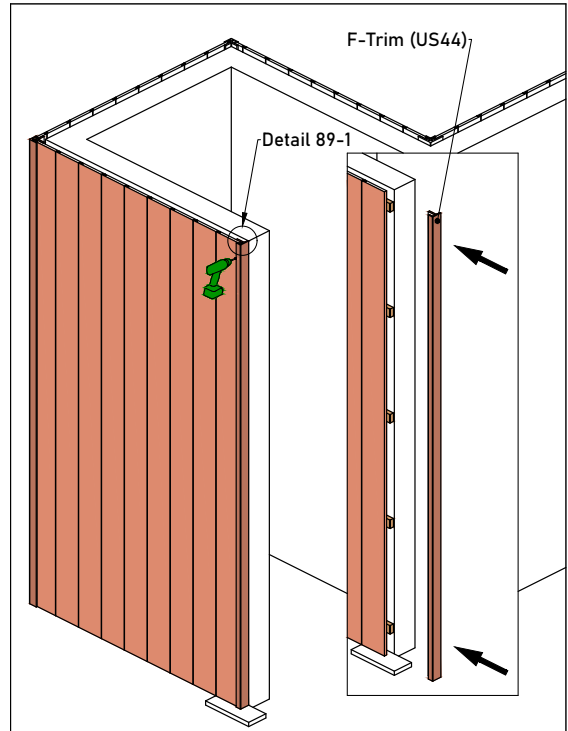


**Diagram 88**

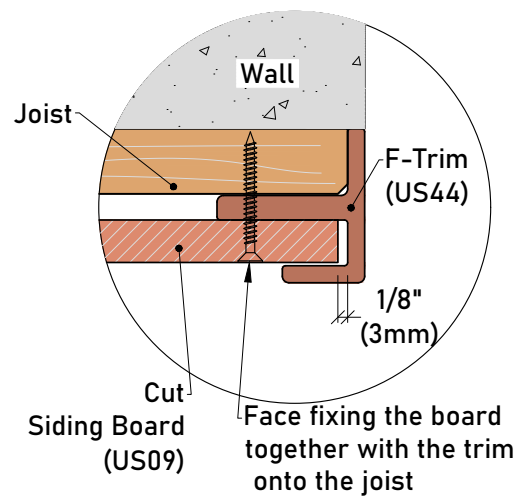


**Detail 88-1**

- 26 Insert the F-Trim (US44) in place. On the top of the cut Siding Board (US09), face fix it together with the F-Trim (US44) onto the joist, as shown in **Diagram 89** and **Detail 89-1**.

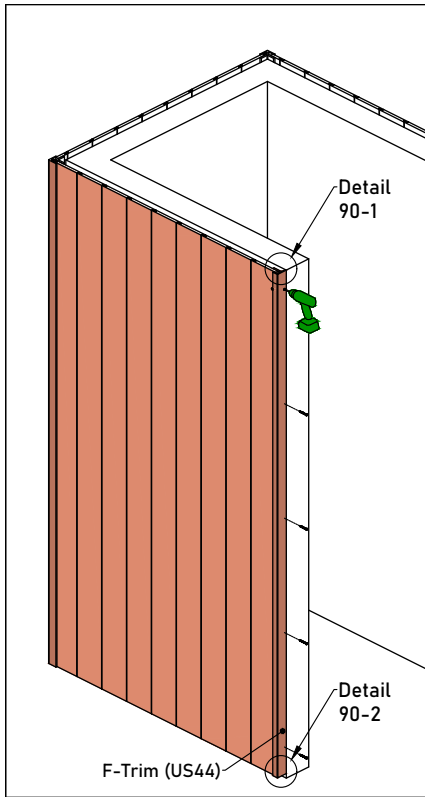


**Diagram 89**

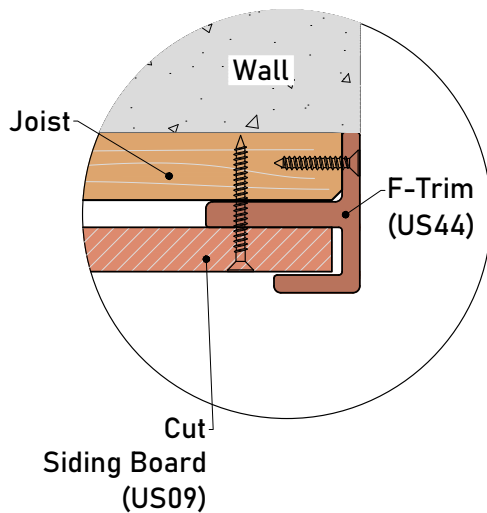


**Detail 89-1**

- 27** Secure the F-Trim (US44) onto the joists with screws, as shown in **Diagram 90** and **Detail 90-1**.



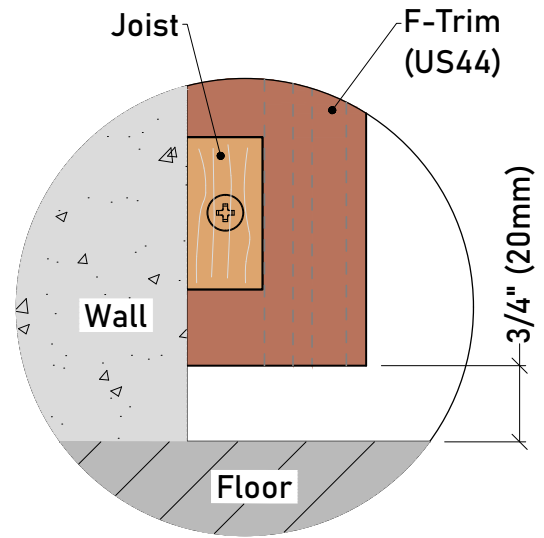
**Diagram 90**



**Detail 90-1**

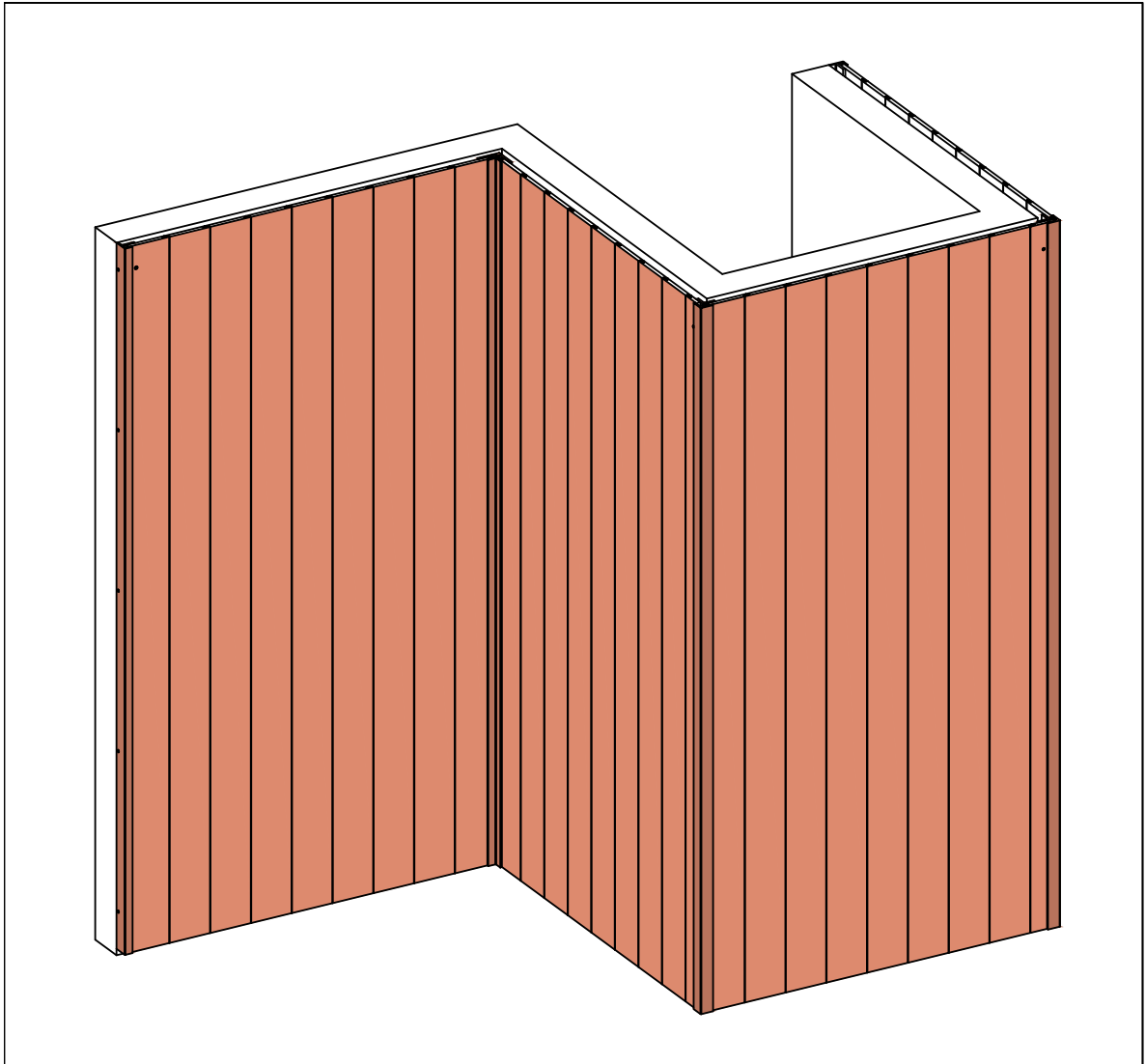
**Note:**

1. Pre-drill the holes on the F-Trim (US44) before installation.
2. A minimum gap of 3/4" (20mm) needs to be left between the F-Trim (US44) and the floor, as shown in **Detail 90-2**.



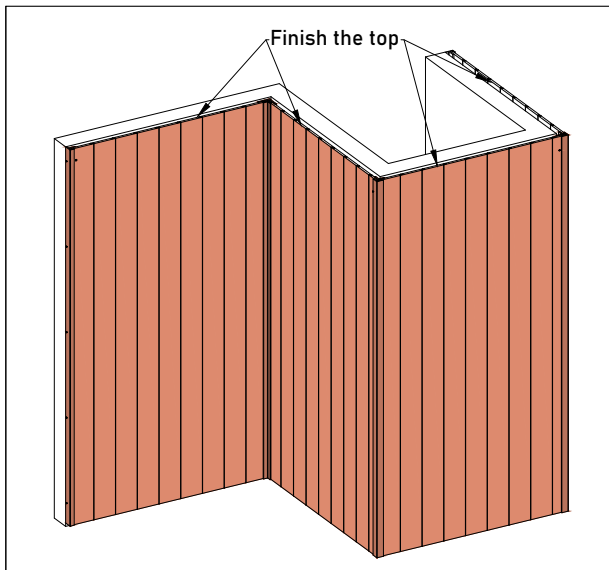
**Detail 90-2**

28 **Diagram 91** presents the final appearance after completing the installation.



**Diagram 91**

**29 Finish the Top**

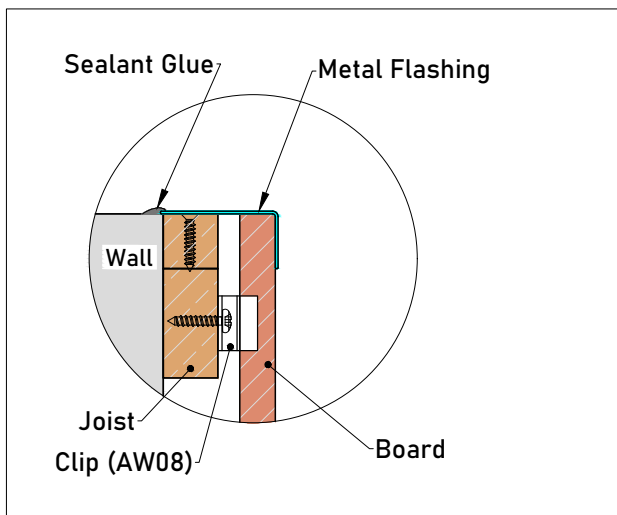


**Diagram 92**

There are two options recommended to finish the top of the siding.

**30 Option 1**

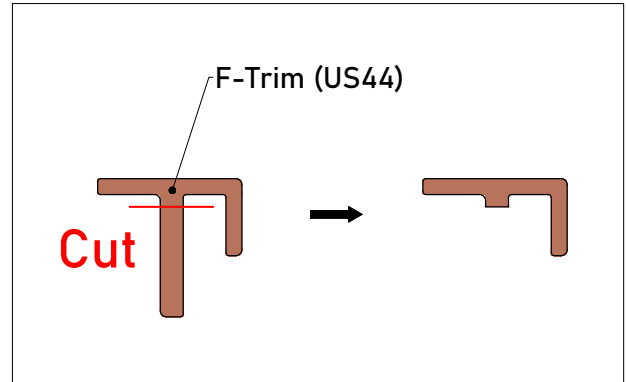
Put a metal flashing over the siding top and fix it onto the joist with screws, as shown in **Diagram 93**.



**Diagram 93**

**31 Option 2**

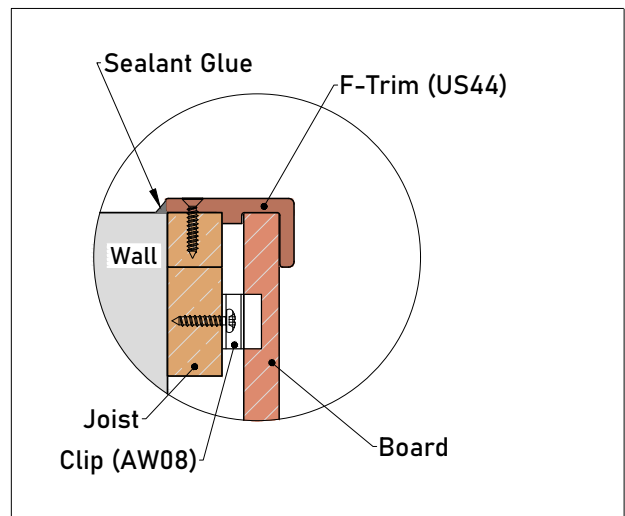
Cut the F-trim (US44) to make the centerpiece shorter without interfering with the Clip (AW08), as shown in **Diagram 94**.



**Diagram 94**

**32**

Put the cut F-Trim (US44) in place and secure it onto the joist with screws, as shown in **Diagram 95**.



**Diagram 95**





## Siding - Vertical Installation Guide

v20210114US

©2021 Huidong Meixin Plastic Lumber Products Manufacturing Co., Ltd.  
NewTechWood® is a registered trademark of Huidong Meixin Plastic Lumber Products Manufacturing Co., Ltd. To obtain a copy of the most current version of this installation guide, visit us online at [www.newtechwood.com](http://www.newtechwood.com).

